

MODEL NO. : TM043YDHG30-00
ISSUED DATE: 2015-5-26
VERSION : 1.1

- Preliminary Specification
 Final Product Specification

Customer : _____

Approved by	Notes

TIANMA Confirmed :

Prepared by	Checked by	Approved by

This technical specification is subjected to change without notice

Table of Contents

Table of Contents.....	2
Record of Revision	3
1 Features	4
2 General Specifications	4
3 Input/Output Terminals.....	5
4 Absolute Maximum Ratings	7
5 Electrical Characteristics.....	8
6 Timing Chart	9
7 Optical Characteristics	14
8 Environmental / Reliability Test specifications	17
9 Mechanical Drawing	18
10 Packing Drawing.....	19
11 Precautions for Use of LCD Modules	21

Record of Revision

Rev	Issued Date	Description	Editor
1.0	2014-2-19	V1.0 spec released	Jin Zhao
1.1	2015-5-26	Update View Angles	Bin Wang

1 General Specifications

Feature		Spec
Display Spec.	Size	4.3"
	Resolution	480RGB x 800
	Technology Type	SFT
	Pixel Pitch(mm)	0.117 x 0.117
	Pixel Configuration	R.G.B. Vertical Stripe
	Display Mode	TM with Normally Black
	Surface Treatment	LR
Mechanical Characteristics	LCM (W x H x D) (mm)	61.96 x 104.5 x 1.9
	Active Area(mm)	56.16 x 93.60
	LED Numbers	8LEDs
	Weight (g)	TBD
Electrical Characteristics	Interface	RGB 24bit +SPI
	Color Depth	16.7M
	Driver IC	ILI9806C

Note 1: Viewing direction for best image quality is different from TFT definition. There is a 180 degree shift.

Note 2: Requirements on Environmental Protection: Q/S0002

Note 3: LCM weight tolerance: $\pm 5\%$

2 Input/Output Terminals

Matched connector:FH26-45S-0.3SHW

Pin	Symbol	I/O	Description	Remark
1	GND	P	Ground	
2	LEDA	P	Power Supply for LED	
3	LEDK	P	Power Supply for LED	
4	VCC	P	Power Supply Type2.8V	
5	IOVCC	P	Power Supply Type1.8V or 2.8V	
6	SDO	O	Serial data output pin for SPI interface	
7	SDI	I	Serial data input pin for SPI interface	
8	GND	P	Ground	
9	SCL_WR	I	Serial clock input	
10	CS	I	Chip select input. Low: select and accessible High: not select and not accessible	
11	IM3	-	NC	
12	RESET	I	Reset pin. Initializes the LSI when low. Must be reset after power-on	
13	R0	I	Data bus pin	
14	R1	I	Data bus pin	
15	R2	I	Data bus pin	
16	R3	I	Data bus pin	
17	R4	I	Data bus pin	
18	R5	I	Data bus pin	
19	R6	I	Data bus pin	
20	R7	I	Data bus pin	
21	G0	I	Data bus pin	
22	G1	I	Data bus pin	
23	G2	I	Data bus pin	
24	G3	I	Data bus pin	
25	G4	I	Data bus pin	
26	G5	I	Data bus pin	

The information contained herein is the exclusive property of TIANMA MICRO-ELECTRONICS Corporation, and shall not be distributed, reproduced, or disclosed in whole or in part without prior written permission of TIANMA MICRO-ELECTRONICS Corporation.

27	G6	I	Data bus pin	
28	G7	I	Data bus pin	
29	B0	I	Data bus pin	
30	B1	I	Data bus pin	
31	B2	I	Data bus pin	
32	B3	I	Data bus pin	
33	B4	I	Data bus pin	
34	B5	I	Data bus pin	
35	B6	I	Data bus pin	
36	B7	I	Data bus pin	
37	DE	I	Data Enable signal Low: access enabled High: access inhibited	
38	GND	P	Ground	
39	PCLK	I	Pixel clock signal	
40	GND	P	Ground	
41	HS	I	Line synchronizing signal	
42	VS	I	Frame synchronizing signal	
43	IC_ID	-	No connect (Test pin)	
44	LED_PWM	O	LED PWM frequency output for LED driver control Leave it open when not in use	
45	GND	P	Ground	

Note: I---Input, O---Output, P--- Power/Ground

3 Absolute Maximum Ratings

GND=0V, Ta = 25°C

Item	Symbol	Min	Max	Unit	Remark
Power supply voltage1(I/O)	IOVCC	-0.3	4.6	V	
Power supply voltage2(Analog)	VCC	-0.3	4.6	V	
Operating Temperature	TOPR	-20	70	°C	
Storage Temperature	TSTG	-30	80	°C	

4 Electrical Characteristics

5.1 LCD DC Characteristics

GND=0V, Ta = 25°C

Item	Symbol	MIN	TYP	MAX	Unit	Remark	
Logic operation Voltage	IOVCC	1.65	1.8/2.8	3.3	V		
Analog operation Voltage	VCC	2.6	2.8	3.3	V		
Input Signal Voltage	High Level	VIH	0.7* IOVCC	-	IOVCC	V	
	Low Level	VIL	-0.3	-	0.3*IOVCC	V	
Output Signal Voltage	High Level	VOH	0.8*IOVCC	-	IOVCC	V	IOH=-1mA
	Low Level	VOL	0	-	0.2*IOVCC	V	IOH=1mA
(Panel+LSI) Power Consumption	White Mode	-	99	150	mW	2.8V	

Table 5.1 LCD module electrical characteristics

5.2 Backlight Characteristics

GND=0V, Ta = 25°C

Item	Symbol	MIN	TYP	MAX	Unit	Remark
Forward Current	I _F	-	20	-	mA	Per 1 LEDs string
Forward Voltage	V _F	-	25.6	-	V	Per 1 LEDs string
Backlight Power Consumption	W _{BL}	-	512	-	mW	8 LEDs

Table 5.2 backlight unit electrical characteristics

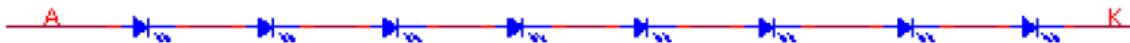
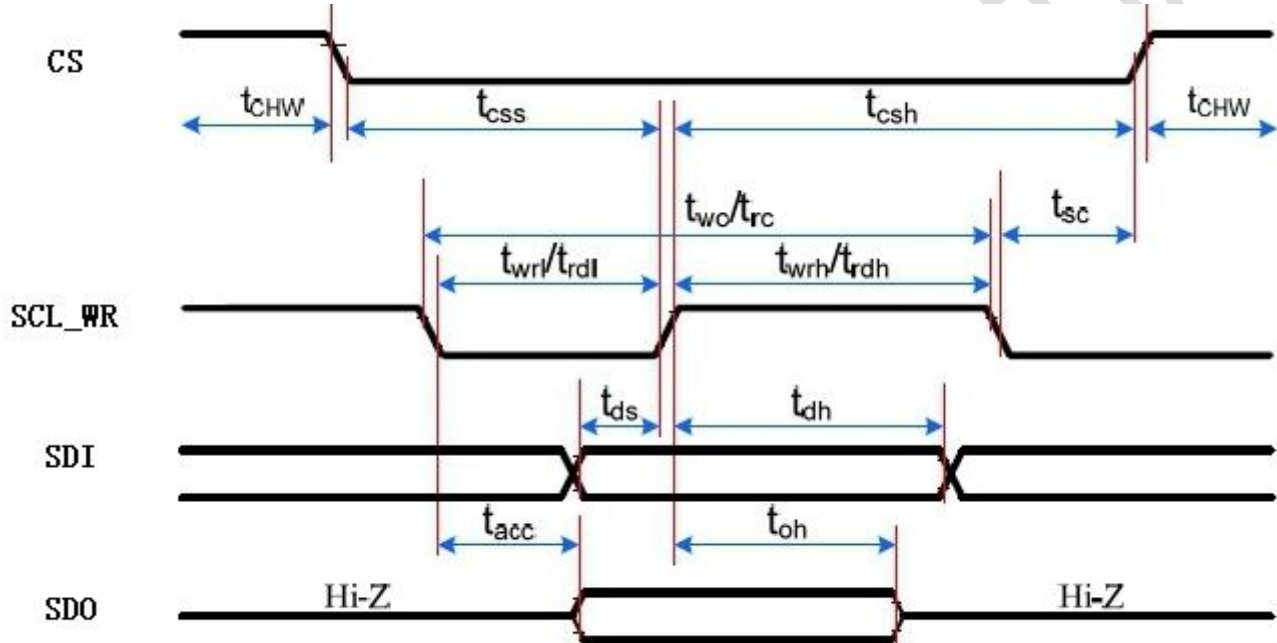

Figure 5.2 LED driver circuit

5 Timing Chart

5.1 Serial Interface Characteristics

5.1.1 Serial Interface Timing



GND=0V, Ta = 25°C

Signal	Symbol	Parameter	min	max	Unit	Description
CS	tcSS	Chip select time(Write)	15	-	ns	
	tcsh	Chip select hold time(Read)	15	-	ns	
	tCHW	CS"H"pulse width	40	-	ns	
SCL_WR	twc	Serial clock cycle(Write)	30	-	ns	
	twrh	SCL"H"pulse width(Write)	10	-	ns	
	twrl	SCL"L"pulse width(Write)	10	-	ns	
	trc	Serial clock cycle(Read)	150	-	ns	
	trdh	SCL"H"pulse width(Read)	60	-	ns	
	trdl	SCL"L"pulse width(Read)	60	-	ns	
SDO	tacc	Access time(Read)	10	50	ns	For maximum CL=30pF For minimum CL=8pF
	toh	Output disable time(Read)	15	50	ns	
SDI	tds	Data setup time(Write)	10	-	ns	
	tdh	Data hold time(Write)	10	-	ns	

Note: Does not include signal rise and fall times.

The information contained herein is the exclusive property of TIANMA MICRO-ELECTRONICS Corporation, and shall not be distributed, reproduced, or disclosed in whole or in part without prior written permission of TIANMA MICRO-ELECTRONICS Corporation.

5.2 RGB Interface Characteristics

5.2.1 RGB Interface Timing

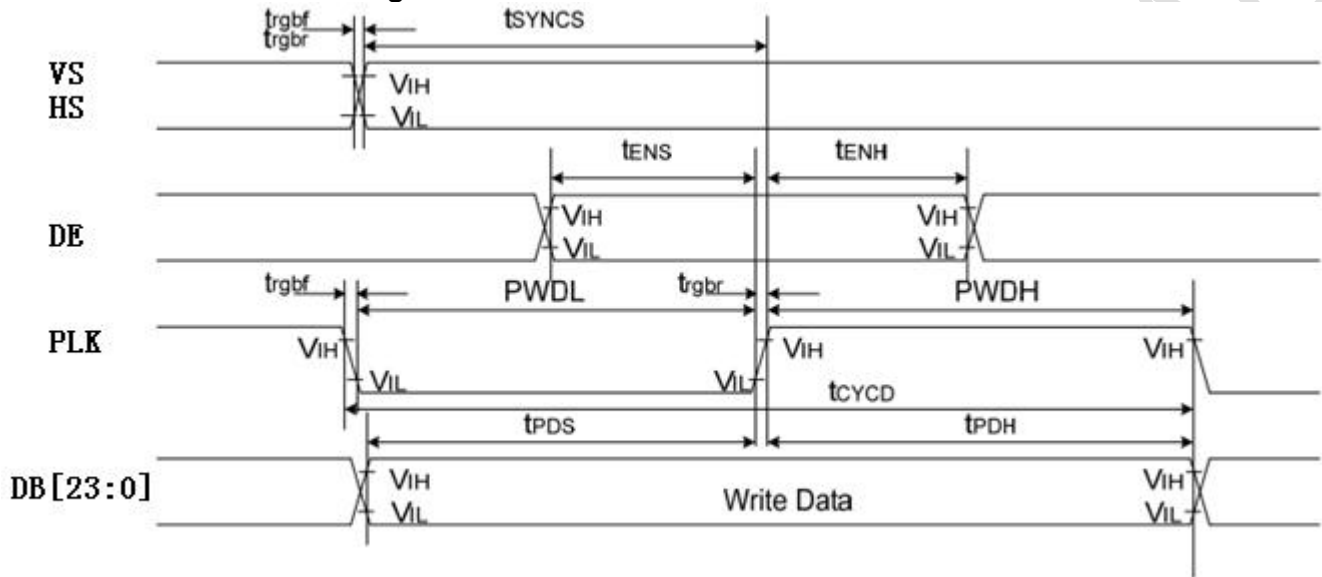

Signal	Symbol	Parameter	min	max	Unit	Description
VS/HS	tSYNCS	VS/HS setup time	5	-	ns	24/18/16-bit bus RGB interface mode
	tSYNCH	VS/HS hold time	5	-	ns	
DE	tENS	DE setup time	5	-	ns	
	tENH	DE hold time	5	-	ns	
DB[23:0]	tPOS	Data setup time	5	-	ns	
	tPDH	Data hold time	5	-	ns	
PLK	PWDH	PLK high-level period	13	-	ns	
	PWDL	PLK low-level period	13	-	ns	
	tCYCD	PLK cycle time	28	-	ns	
	trgbr, trgbf	PLK, HS, VS rise/fall time	-	15	ns	

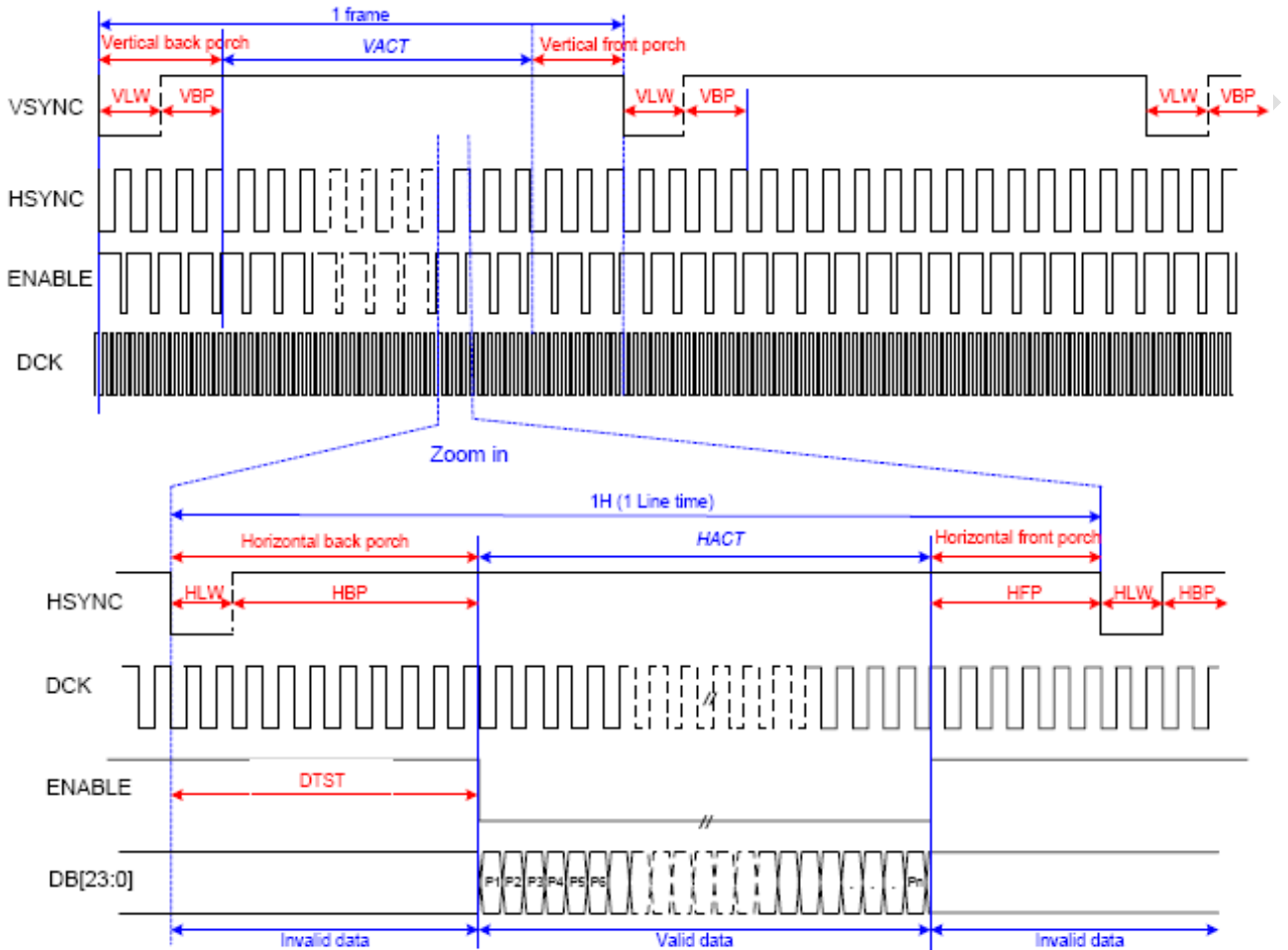

VLW : VSYNC Low pulse Width
 HLW : HSYNC Low pulse Width
 DTST : Data Transfer Startup Time
 Pn : pixel 1, pixel 2..., pixel n.

Parameters	Symbols	Condition	Min.	Typ.	Max.	Units
Frame Rate	FR		50	-	70	fps
Horizontal Low Pulse Width	HLW		5	-	80	DOTCLK
Horizontal Back Porch	HBP		10	-	85	DOTCLK
Horizontal Address	HACT		-	480	-	DOTCLK
Horizontal Front Porch	HFP		5	-	80	DOTCLK
Horizontal Blanking Period	HBP + HFP		60		90	DOTCLK
Vertical Low Pulse Width	VLW		2	-	4	Line
Vertical Back Porch*	VBP		4	-		Line
Vertical Address	VACT		-	800	-	Line
Vertical Front Porch	VFP		2	-		Line
Vertical Blanking Period	VBP + VFP		6			Line
Data Clock	DCLK		23.5	-	34.9	MHz

5.3 Reset Input Timing

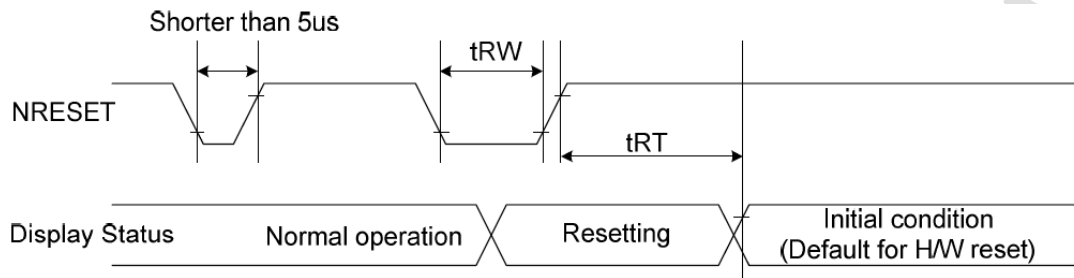

Figure 6.4: Reset input timing

GND=0V, Ta = 25°C

Signal	Symbol	Parameter	min	max	Unit
RESET	tRW	Reset pulse duration	10		us
	tRT	Reset cancel		5(note 1,5) 120(note 1,6,7)	ms

Note:

1.The reset cancel includes also required time for loading ID bytes,VCOM setting and other settings from OTP to registers.This loading is done every time when there is H/W reset cancel time (tRT) within 5 ms after a rising edge of RESET.

2.Spike due to an electrostatic discharge on RESET line does not cause irregular system reset according to following table.

RESET Pulse	Action
Shorter than 5us	Reset Rejected
Longer than 9us	Reset
Between 5us and 9us	Reset stars

3.During the Resetting period, the display will be blanked(The display is entering blanking sequence, which maximum time is 120 ms, when Reset Starts in Sleep Out mode. The display remains the blank state in Sleep In mode.) and then return to Default condition for Hardware Reset.

4.Spike Rejection also applies during a valid reset pulse as shown

below:

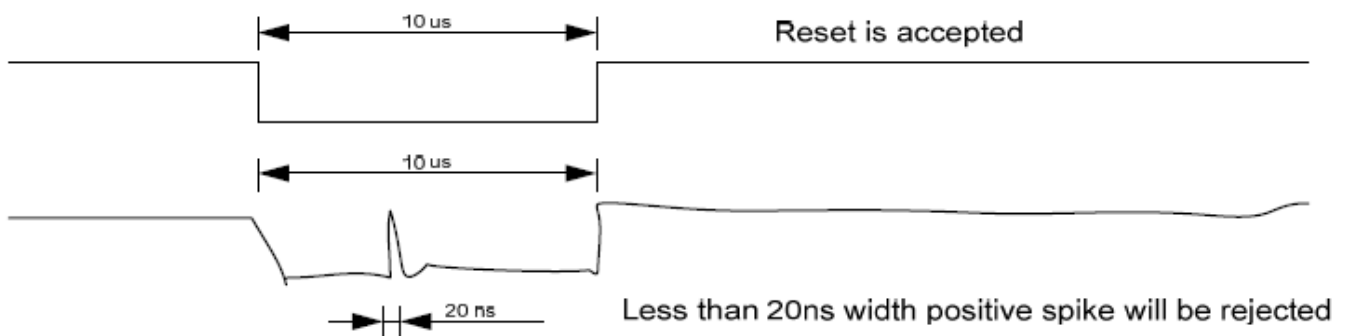

5.When Reset applied during Sleep In Mode.

6.When Reset applied during Sleep Out Mode.

7.It is necessary to wait 5msec after releasing RESET before sending commands.Also Sleep Out command cannot be sent for 120msec.

5.4 Power ON/OFF Timing

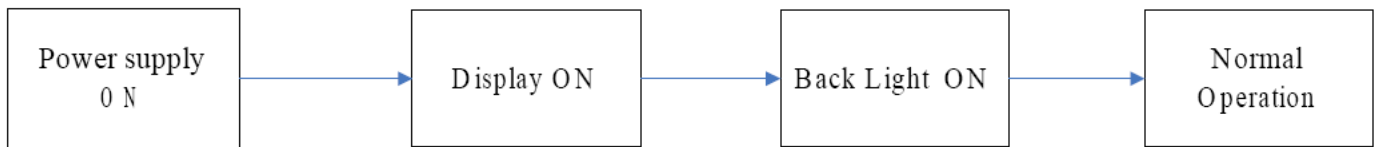
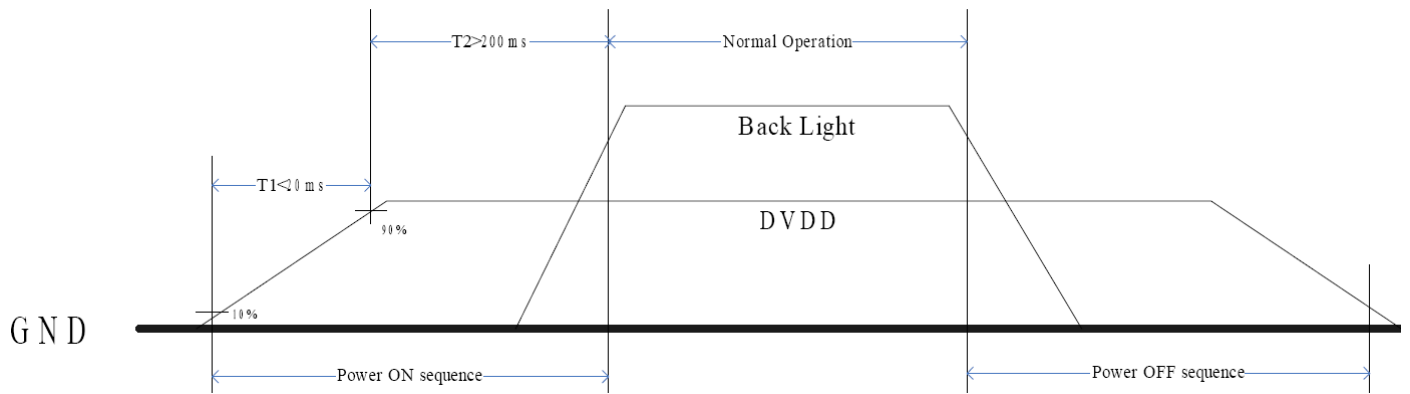

Power ON Sequence

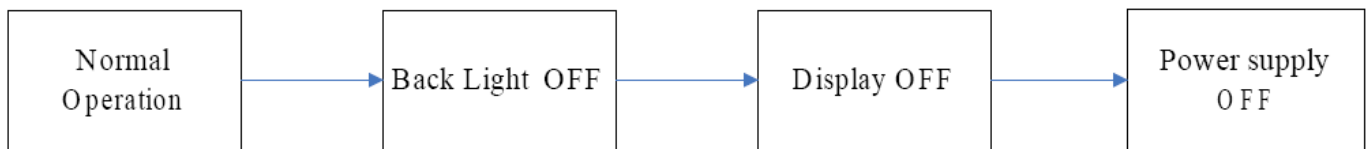

Power OFF Sequence

6 Optical Characteristics

Ta=25°C

Item	Symbol	Condition	Min	Typ	Max	Unit	Remark
View Angles	θT	CR ≥ 10	75	85	-	Degree	Note2,3
	θB		75	85	-		
	θL		75	85	-		
	θR		75	85	-		
Contrast Ratio	CR	θ=0°	600	800	-		Note 3
Response Time	T _{ON}	25°C	-	35	50	ms	Note 4
	T _{OFF}						
Chromaticity	White	Backlight is on	x	0.253	0.303	0.353	Note 1,5
			y	0.275	0.325	0.375	
	Red		x	0.587	0.637	0.687	Note 1,5
			y	0.308	0.358	0.408	
	Green		x	0.264	0.314	0.364	Note 1,5
			y	0.540	0.590	0.640	
	Blue		x	0.102	0.152	0.202	Note 1,5
			y	0.015	0.065	0.115	
Uniformity	U		75	80		%	Note 6
NTSC			60	65		%	Note 5
Luminance	L		250	300		cd/m ²	Note 7

Test Conditions:

1. I_F= 22 mA, and the ambient temperature is 25°C.
2. The test systems refer to Note 1 and Note 2.

Note 1: Definition of optical measurement system.

The optical characteristics should be measured in dark room. After 5 Minutes operation, the optical properties are measured at the center point of the LCD screen. All input terminals LCD panel must be ground when measuring the center area of the panel.

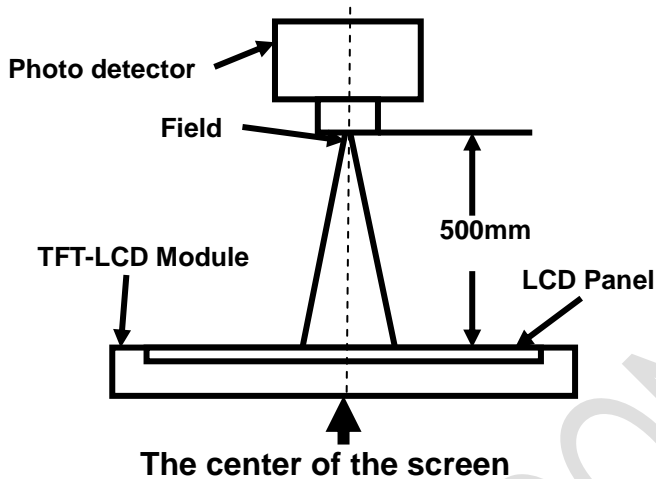

Item	Photo detector	Field
Contrast Ratio	SR-3A	1°
Luminance		
Chromaticity		
Lum Uniformity		
Response Time	BM-7A	2°

Note

2: Definition of viewing angle range and measurement system.

viewing angle is measured at the center point of the LCD by CONOSCOPE(ergo-80).

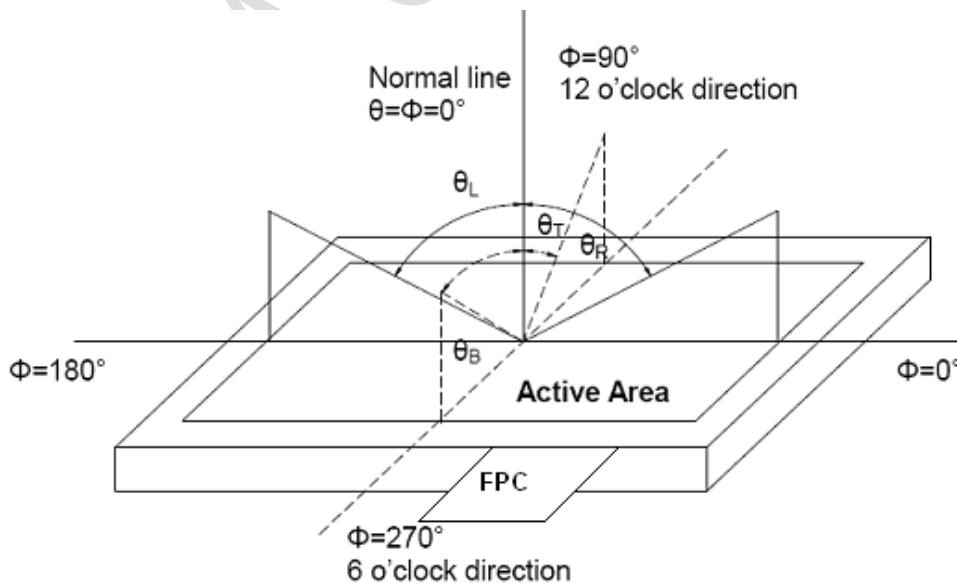

Note 3: Definition of contrast ratio

$$\text{Contrast ratio (CR)} = \frac{\text{Luminance measured when LCD is on the "White" state}}{\text{Luminance measured when LCD is on the "Black" state}}$$

“White state “: The state is that the LCD should drive by V_{white} .

“Black state”: The state is that the LCD should drive by V_{black} .

V_{white} : To be determined V_{black} : To be determined.

The information contained herein is the exclusive property of TIANMA MICRO-ELECTRONICS Corporation, and shall not be distributed, reproduced, or disclosed in whole or in part without prior written permission of TIANMA MICRO-ELECTRONICS Corporation.

Note 4: Definition of Response time

The response time is defined as the LCD optical switching time interval between “White” state and “Black” state. Rise time (T_{ON}) is the time between photo detector output intensity changed from 90% to 10%. And fall time (T_{OFF}) is the time between photo detector output intensity changed from 10% to 90%.

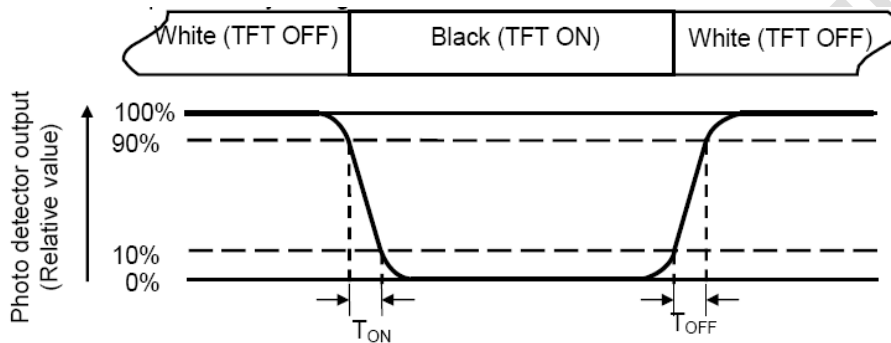

Note 5: Definition of color chromaticity (CIE1931)

Color coordinates measured at center point of LCD.

Note 6: Definition of Luminance Uniformity

Active area is divided into 9 measuring areas (Refer Fig. 2). Every measuring point is placed at the center of each measuring area.

$$\text{Luminance Uniformity (U)} = L_{\min} / L_{\max}$$

L-----Active area length W----- Active area width

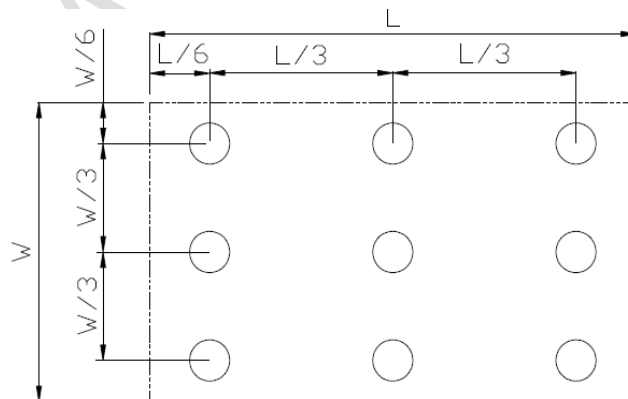

L_{\max} : The measured Maximum luminance of all measurement position.

L_{\min} : The measured Minimum luminance of all measurement position.

Note 7: Definition of Luminance:

Measure the luminance of white state at center point.

7 Environmental / Reliability Test specifications

No	Test Item	Condition	Remarks
1	High Temperature Operation	Ts=+70°C, 240hrs	Note1 IEC60068-2-2,GB2423.2—89
2	Low Temperature Operation	Ta=-20°C, 240hrs	Note 2, IEC60068-2-1 GB2423.1—89
3	High Temperature Storage	Ta=+80°C, 240hrs	IEC60068-2-2, GB2423.2—89
4	Low Temperature Storage	Ta=-30°C, 240hrs	IEC60068-2-1 GB2423.1—89
5	High Temperature & High Humidity (Non-Operation)	+60°C, 90% RH max, 240 hours	IEC60068-2-3, GB/T2423.3—2006
6	Thermal Shock (non-operation)	-30°C 30 min~+70°C 30 min, Change time:5min, 20 Cycle	Start with cold temperature, end with high temperature IEC60068-2-14,GB2423.22—87
7	Electro Static Discharge (operation)	C=150pF, R=330Ω, 5points/panel Air:±8KV, 5times; Contact:±4KV, 5 times; (Environment:15°C~35°C,3 0%~60%, 86Kpa~106Kpa)	IEC61000-4-2 GB/T17626.2—1998
8	Vibration (non-operation)	Frequency range:10~55Hz, Stroke:1.5mm Sweep:10Hz~55Hz~10Hz 2 hours for each direction of X.Y.Z.(package condition)	IEC60068-2-6 GB/T2423.10—1995
9	Shock (non-operation)	60G 6ms, ±X,±Y,±Z 3times for each direction	IEC60068-2-27 GB/T2423.5—1995
10	Package Drop Test	Height:60 cm, 1 corner, 3 edges, 6 surfaces	IEC60068-2-32 GB/T2423.8—1995

Note1: Ts is the temperature of panel's surface.

Note2: Ta is the ambient temperature of sample.

Note3: Before cosmetic and function test, the product must have enough recovery time, at least 2 hours at room temperature.

8 Mechanical Drawing

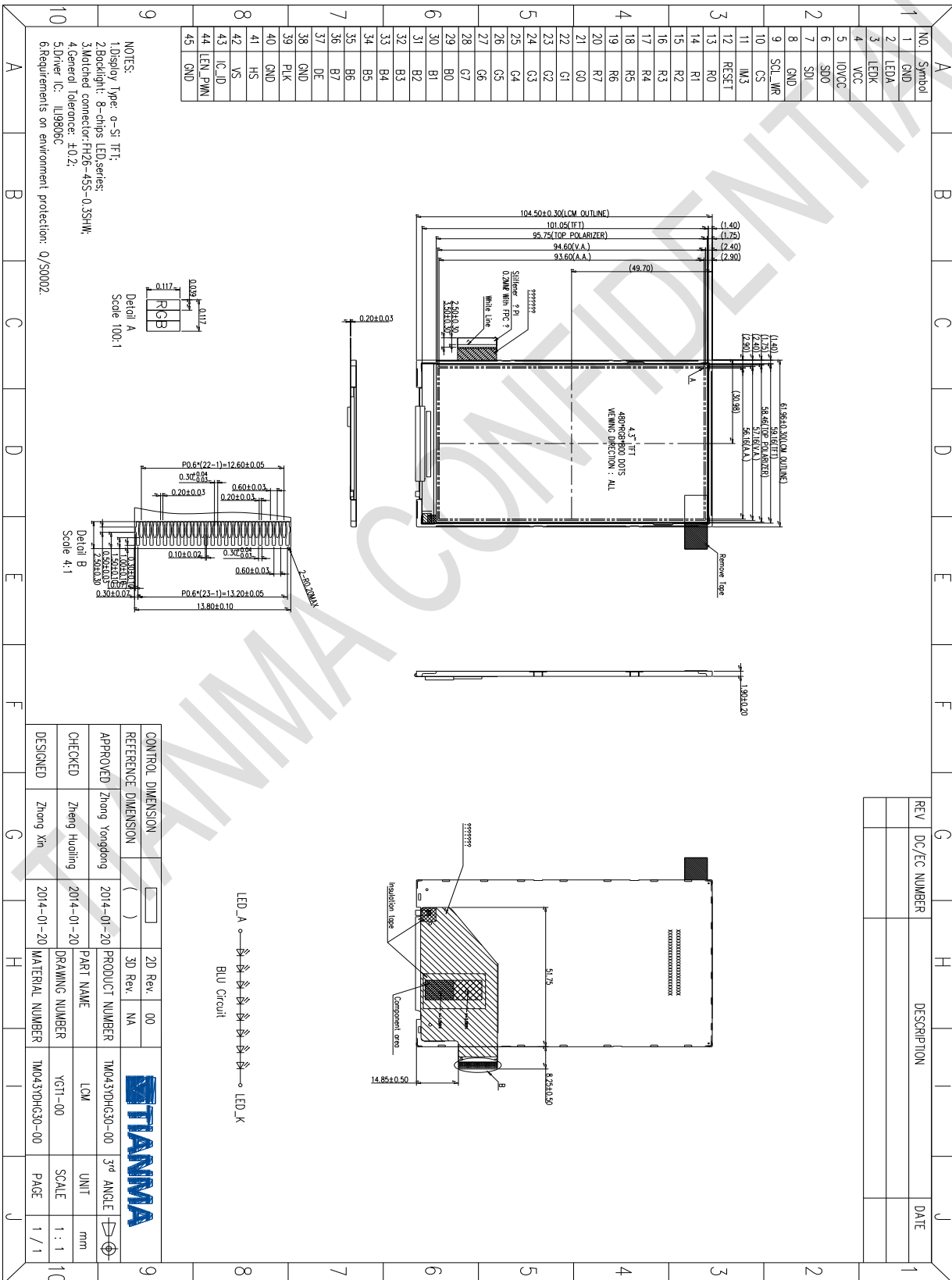

The information contained herein is the exclusive property of TIANMA MICRO-ELECTRONICS Corporation, and shall not be distributed, reproduced, or disclosed in whole or in part without prior written permission of TIANMA MICRO-ELECTRONICS Corporation.

9 Packing Drawing

No	Item	Model (Materiel)	Dimensions(mm)	Unit Weight(Kg)	Quantity	Remark
1	LCM Module	TM043YDHG30-00	61.96 x 104.5 x 1.9	TBD	180	
2	Tray	PET (Transmit)	485×330×13.8	0.161	21	Anti-static
3	Dust-Proof Bag	PE	700×545	0.046	1	
4	BOX	Corrugated Paper	520×345×74	0.369	3	
5	Desiccant	Desiccant	45×35	0.002	6	
6	EPE	EPE	485×330×5	0.015	3	
7	Carton	Corrugated Paper	544×365×250	0.76	1	
	Total Weight		TBD			

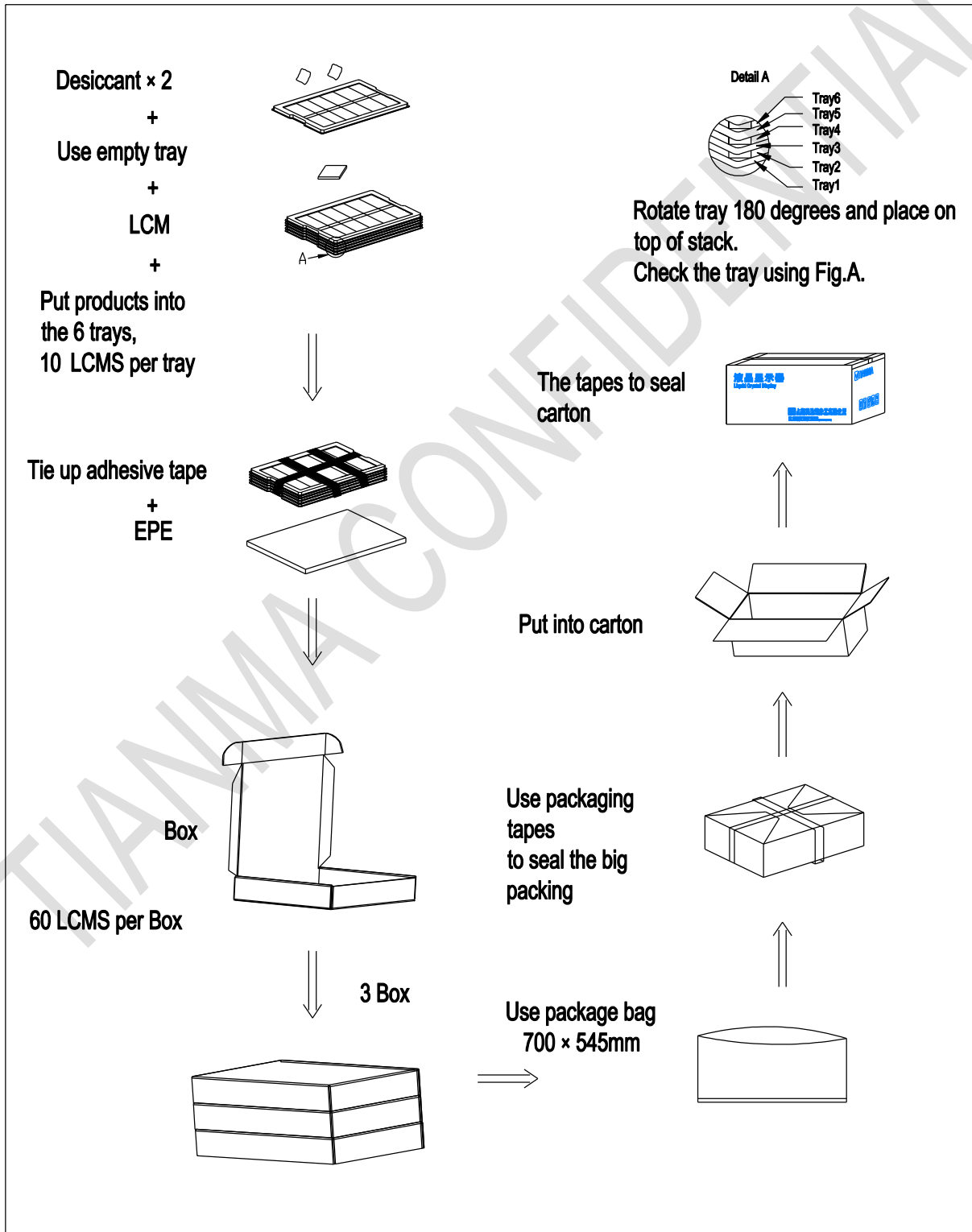

10 Precautions for Use of LCD Modules

10.1 Handling Precautions

10.1.1 The display panel is made of glass. Do not subject it to a mechanical shock by dropping it from a high place, etc.

10.1.2 If the display panel is damaged and the liquid crystal substance inside it leaks out, be sure not to get any in your mouth, if the substance comes into contact with your skin or clothes, promptly wash it off using soap and water.

10.1.3 Do not apply excessive force to the display surface or the adjoining areas since this may cause the color tone to vary.

10.1.4 The polarizer covering the display surface of the LCD module is soft and easily scratched. Handle this polarizer carefully.

10.1.5 If the display surface is contaminated, breathe on the surface and gently wipe it with a soft dry cloth. If still not completely clear, moisten cloth with one of the following solvents:

- Isopropyl alcohol
- Ethyl alcohol

Solvents other than those mentioned above may damage the polarizer. Especially, do not use the following:

- Water
- Ketone
- Aromatic solvents

10.1.6 Do not attempt to disassemble the LCD Module.

10.1.7 If the logic circuit power is off, do not apply the input signals.

10.1.8 To prevent destruction of the elements by static electricity, be careful to maintain an optimum work environment.

10.1.8.1 Be sure to ground the body when handling the LCD Modules.

10.1.8.2 Tools required for assembly, such as soldering irons, must be properly ground.

10.1.8.3 To reduce the amount of static electricity generated, do not conduct assembly and other work under dry conditions.

10.1.8.4 The LCD Module is coated with a film to protect the display surface. Be care when peeling off this protective film since static electricity may be generated.

10.2 Storage precautions

10.2.1 When storing the LCD modules, avoid exposure to direct sunlight or to the light of fluorescent lamps.

10.2.2 The LCD modules should be stored under the storage temperature range. If the LCD modules will be stored for a long time, the recommend condition is:

Temperature : 0°C ~ 40°C Relatively humidity: ≤80%

10.2.3 The LCD modules should be stored in the room without acid, alkali and harmful gas.

10.3 Transportation Precautions

10.3.1 The LCD modules should be no falling and violent shocking during transportation, and also should avoid excessive press, water, damp and sunshine.