

MODEL NO. : TM070RDH12ISSUED DATE: 2013-06-19VERSION : Ver 2.2

- Preliminary Specification  
 Final Product Specification

Customer : \_\_\_\_\_

Approved by	Notes

SHANGHAI TIANMA Confirmed :

Prepared by	Checked by	Approved by
Guangqing Zhou 2013/06/19	Jun Xiao 2013/06/19	Peng Peng 2013/06/19

This technical specification is subjected to change without notice

The information contained herein is the exclusive property of SHANGHAI TIANMA MICRO-ELECTRONICS Corporation, and shall not be distributed, reproduced, or disclosed in whole or in part without prior written permission of SHANGHAI TIANMA MICRO-ELECTRONICS Corporation.



## Table of Contents

Table of Contents.....	2
Record of Revision.....	3
1. General Specifications.....	4
2. Input/Output Terminals.....	5
3. Absolute Maximum Ratings.....	7
4. Electrical Characteristics.....	8
5. Timing Chart.....	13
6. Optical Characteristics.....	17
7. Environmental / Reliability Test.....	20
8. Mechanical Drawing.....	21
9. Packing Drawing.....	22
10. Precautions for Use of LCD Modules.....	24



### Record of Revision

Rev	Issued Date	Description	Editor
1.0	2010-06-07	Preliminary Specification Release	Xing Nie
2.0	2010-08-26	Final Product Specification Release	Xing Nie
2.1	2011-12-31	Update Operating Life Time in page 11	Xing Nie
2.2	2013-06-19	Update Gamma Correction Reference Voltage in page 9~10	Guangqing Zhou

The information contained herein is the exclusive property of SHANGHAI TIANMA MICRO-ELECTRONICS Corporation, and shall not be distributed, reproduced, or disclosed in whole or in part without prior written permission of SHANGHAI TIANMA MICRO-ELECTRONICS Corporation.



## 1 General Specifications

Feature		Spec
<b>Display Spec.</b>	Size	7.0 inch
	Resolution	800(RGB) x 480
	Interface	RGB 24 bit with TCON
	Color Depth	16.7M
	Technology Type	a-Si
	Pixel Pitch (mm)	0.1926x0.1790
	Pixel Configuration	R.G.B. Vertical Stripe
	Display Mode	TM with Normally White
	Surface Treatment(Up Polarizer)	Anti Glare
	Viewing Direction	12 o'clock
	Gray Scale Inversion Direction	6 o'clock
<b>Mechanical Characteristics</b>	LCM (W x H x D) (mm)	164.9x100.0x5.7
	Active Area(mm)	154.08X85.92
	With /Without TSP	Without TSP
	Weight (g)	165
	LED Numbers	21 LEDs

Note 1: Viewing direction for best image quality is different from TFT definition. There is a 180 degree shift.

Note 2: Requirements on Environmental Protection: Q/S0002

Note 3: LCM weight tolerance: +/- 5%



## 2 Input/Output Terminals

### 2.1 CN1 of FPC

Matching Connector: FH28-60S-0.5SH

Pin No	Symbol	I/O	Description	Remark
1	AGND	P	Ground	
2	AVDD	P	Analog power	
3	VCC	P	Digital power supply	
4	R0	I	Red data(LSB)	
5	R1	I	Red data	
6	R2	I	Red data	
7	R3	I	Red data	
8	R4	I	Red data	
9	R5	I	Red data	
10	R6	I	Red data	
11	R7	I	Red data(MSB)	
12	G0	I	Green data(LSB)	
13	G1	I	Green data	
14	G2	I	Green data	
15	G3	I	Green data	
16	G4	I	Green data	
17	G5	I	Green data	
18	G6	I	Green data	
19	G7	I	Green data(MSB)	
20	B0	I	Blue data(LSB)	
21	B1	I	Blue data	
22	B2	I	Blue data	
23	B3	I	Blue data	
24	B4	I	Blue data	
25	B5	I	Blue data	
26	B6	I	Blue data	
27	B7	I	Blue data(MSB)	
28	DCLK	I	Clock input	
29	DE	I	Data enable signal. Active high to enable data	
30	HSD	I	Horizontal sync input. negative polarity	
31	VSD	I	Vertical sync input. negative polarity	
32	MODE	I	DE/SYNC mode select. H: DE mode ,L: SYNC mode	
33	RSTB	I	Global reset pin	
34	STBYB	I	Standby mode select H: normal operation, L: standby mode	
35	SHLR	I	Source right or left sequence control	
36	VCC	P	Digital power	
37	UPDN	I	Gate up or down scan control	
38	GND	P	Ground	
39	AGND	P	Ground	
40	AVDD	P	Analog power	
41	VCOM	I	Common voltage input	

The information contained herein is the exclusive property of SHANGHAI TIANMA MICRO-ELECTRONICS Corporation, and shall not be distributed, reproduced, or disclosed in whole or in part without prior written permission of SHANGHAI TIANMA MICRO-ELECTRONICS Corporation.



42	DITH	I	Dithering setting. H: 6bit resolution, L: 8bit resolution	
43	NC	-	Not connect	
44	NC	-	Not connect	
45	V10	I	Gamma voltage 10	
46	V9	I	Gamma voltage 9	
47	V8	I	Gamma voltage 8	
48	V7	I	Gamma voltage 7	
49	V6	I	Gamma voltage 6	
50	V5	I	Gamma voltage 5	
51	V4	I	Gamma voltage 4	
52	V3	I	Gamma voltage 3	
53	V2	I	Gamma voltage 2	
54	V1	I	Gamma voltage 1	
55	NC	-	Not connect	
56	VGH	P	Positive power for TFT	
57	VCC	P	Digital power	
58	VGL	P	Negative power for TFT	
59	GND	P	Ground	
60	NC	-	Not connect	

Note: I/O definition.

I---Input pin, O---Output pin, P--- Power/Ground, N--- No Connection

## 2.2 CN2 of LED BLU Connector

Pin	Symbol	I/O	Description	Remark
1	LED+	P	LED Anode	Red Cable
2	LED-	P	LED Cathode	White Cable

## 2.3 U/D R/L Function Description

Scan Control Input		Scanning Direction
UPDN	SHLR	
GND	VCC	Up to Down, Left to Right
VCC	GND	Down to Up, Right to Left
GND	GND	Up to Down, Right to Left
VCC	VCC	Down to Up, Left to Right



### 3 Absolute Maximum Ratings

AGND= GND=0V, Ta = 25°C

Item	Symbol	Min	Max	Unit	Remark
Power Voltage	VCC	-0.50	5.00	V	
	AVDD	-0.50	15.00	V	
	VGH	-0.30	42.00	V	
	VGL	-20.00	0.30	V	
	VGH-VGL	-0.30	40.00	V	
Backlight Forward Current	I <sub>LED</sub>	-	25.0	mA	For each LED
Operating Temperature	T <sub>OPR</sub>	-20.0	70.0	°C	
Storage Temperature	T <sub>STG</sub>	-30.0	80.0	°C	



## 4 Electrical Characteristics

### 4.1 Recommended Operating Condition

AGND=GND=0V, Ta = 25°C

Parameter		Symbol	MIN	TYP	MAX	Unit	Remark
Digital supply Voltage		VCC	3.00	3.30	3.60	V	
Analog supply Voltage		AVDD	10.07	10.60	11.13	V	
Gate on voltage		VGH	14.40	16.00	17.60	V	
Gate off voltage		VGL	-7.70	-7	-6.30	V	
Common Electrode Driving Signal		VCOM	-	4.30	-	V	
Input level of Gamma voltage		V1~V5	0.4*AVDD	-	AVDD-0.4	V	
		V6~V10	0.1	-	0.6*AVDD	V	
Input Signal Voltage	Low Level	V <sub>IL</sub>	0	-	0.3*VCC	V	R0~R7,G0~G7,0~B7,DE, DCLK,HSD,VSD,MODE, RSTB,STBYB,SHLR,UPDN, DITH
	High Level	V <sub>IH</sub>	0.7*VCC	-	VCC	V	
Current of digital supply voltage		I <sub>VCC</sub>	-	-	10	mA	VCC=3.3V color bar pattern
Current of analog supply voltage		I <sub>AVDD</sub>	-	-	40	mA	AVDD=Typ color bar pattern
Current of Gate on voltage		I <sub>VGH</sub>	-	-	0.3	mA	VGH=22.0V
Current of Gate off voltage		I <sub>VGL</sub>	-	-	0.3	mA	VGL=-7.0V

Note: The value is for design stage only.





## 4.2 Gamma Correction Reference Voltage Setting

### Gamma Correction Curve

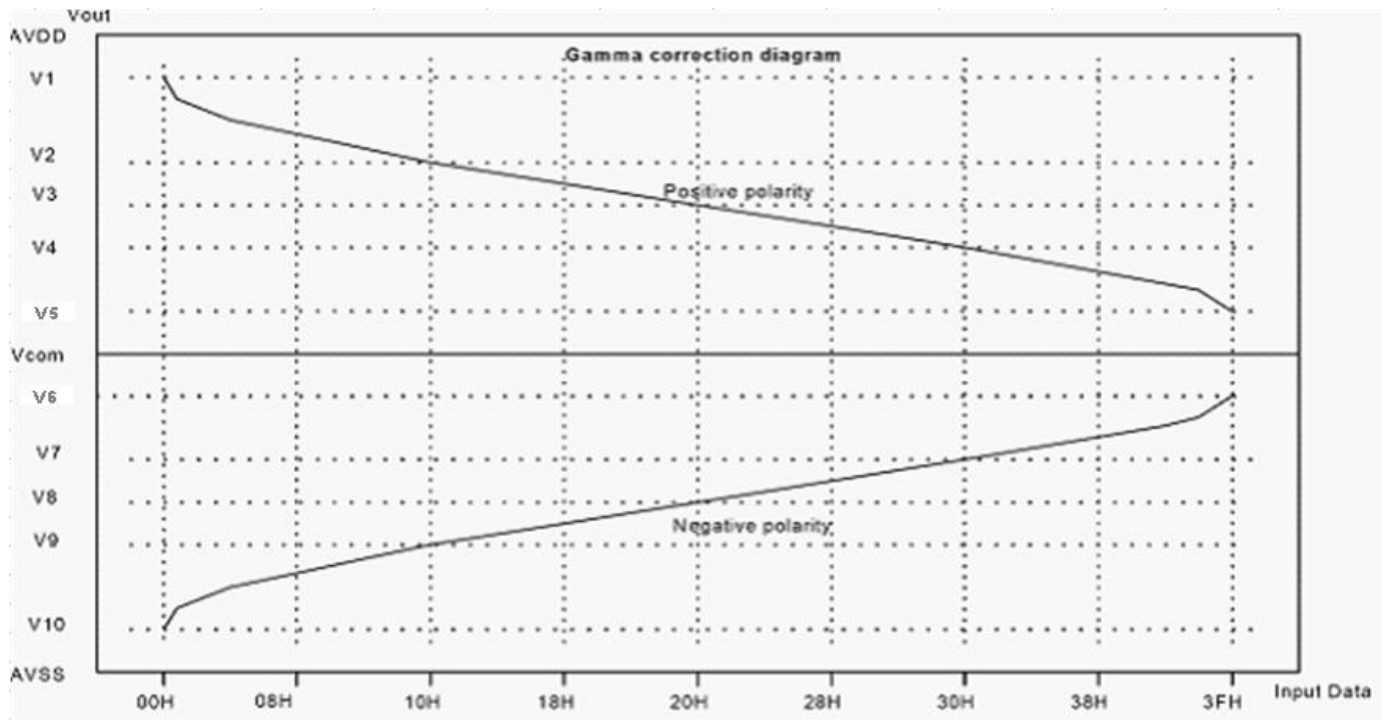

### Gamma Correction Reference Voltage Setting

Parameter	Symbol	MIN	TYP	MAX	Unit	Remark
Gamma correction reference voltage V1~V10	V1	-	10.14	AVDD-0.4	V	
	V2	-	8.25	-	V	
	V3	-	7.66	-	V	
	V4	-	7.19	-	V	
	V5	-	5.50	-	V	
	V6	-	5.10	-	V	
	V7	-	3.41	-	V	
	V8	-	2.94	-	V	
	V9	-	2.35	-	V	
	V10	AGND+0.1	0.46	-	V	

Note: the value is for design stage only;

AVDD-0.4 > V1 > V2 > V3 > V4 > V5 > V6 > V7 > V8 > V9 > V10 > AGND+0.1V



Gamma Correction Reference Circuit

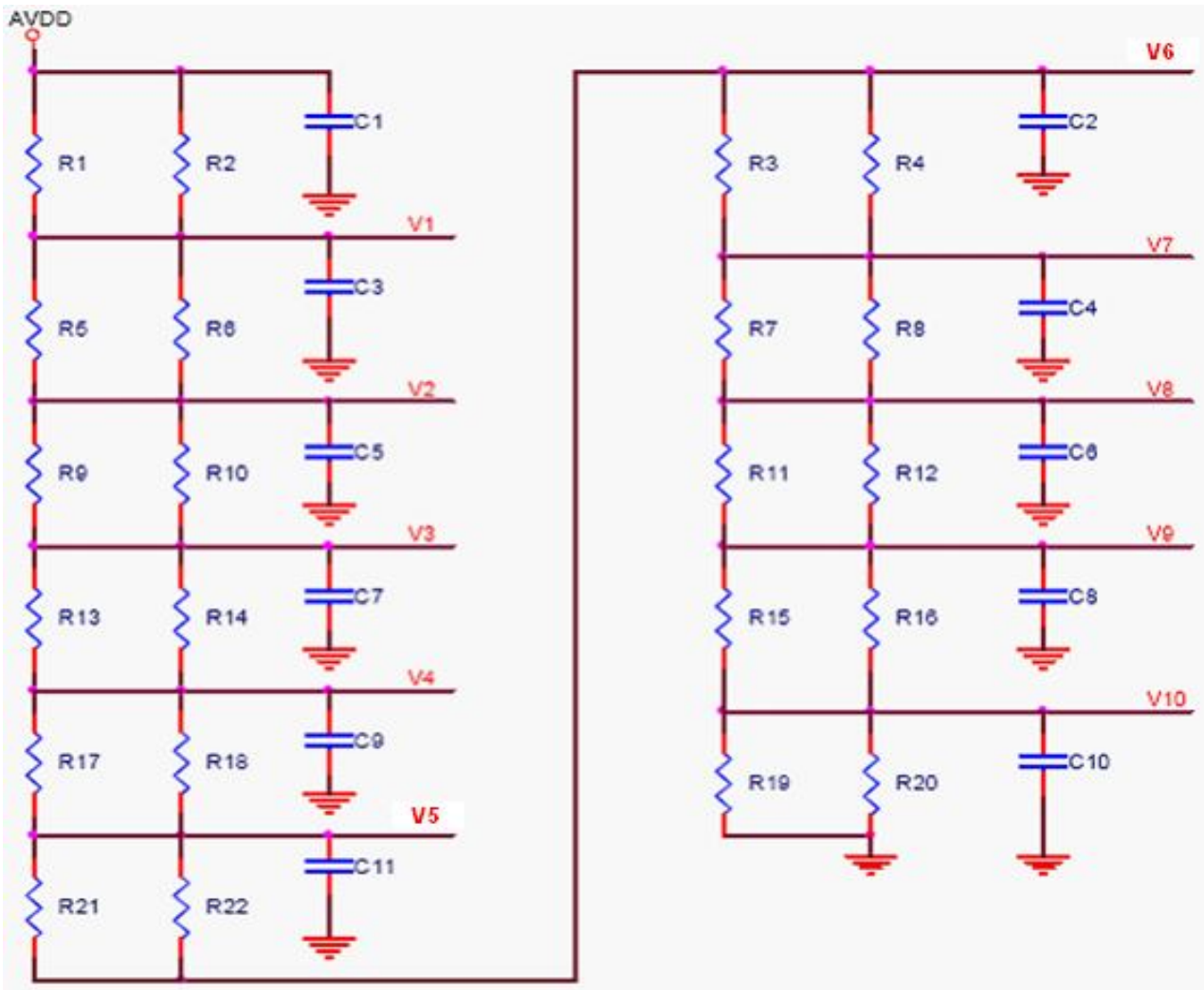

Gamma Correction Resistance Value

Symbol	Unit	Resistance	Symbol	Unit	Resistance
R1// R2	Ω	47//NC	R3// R4	Ω	240//620
R5// R6	Ω	240//1000	R7// R8	Ω	62//220
R9// R10	Ω	91//180	R11// R12	Ω	91//180
R13// R14	Ω	62//220	R15// R16	Ω	240//1000
R17// R18	Ω	240//620	R19// R20	Ω	47//NC
R21// R22	Ω	47//300	C1~C10	uF	1.0 (16V)

Note: Setting the resistance only when AVDD=10.60V, AGND=GND=0V



4.3 Recommended Driving Condition for Backlight

Ta=25°C

Item	Symbol	Min	Typ	Max	Unit	Remark
Forward Current	$I_F$	-	140.0	-	mA	21LEDs (3 LED Serial, 7 LED Parallel)
Forward Voltage	$V_F$	-	9.6	11.4	V	
Backlight Power Consumption	$W_{BL}$	-	1344	-	W	
Operating Life Time	--	10000	20000	--	hrs	

Note 1: The LED driving condition is defined for total backlight consumption, and which depend on Forward Current setting.

Note 2: Forward Voltage is just for reference for one serial.

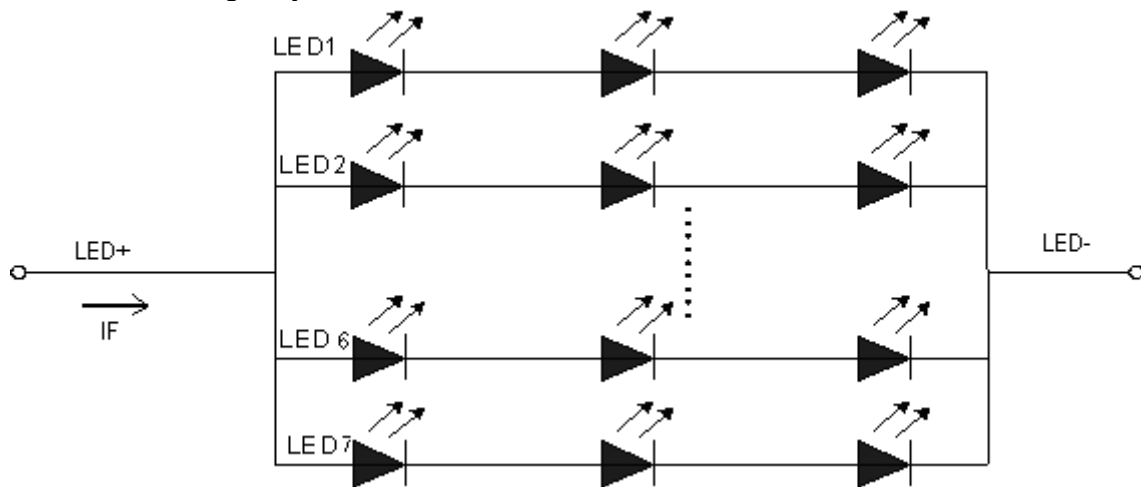

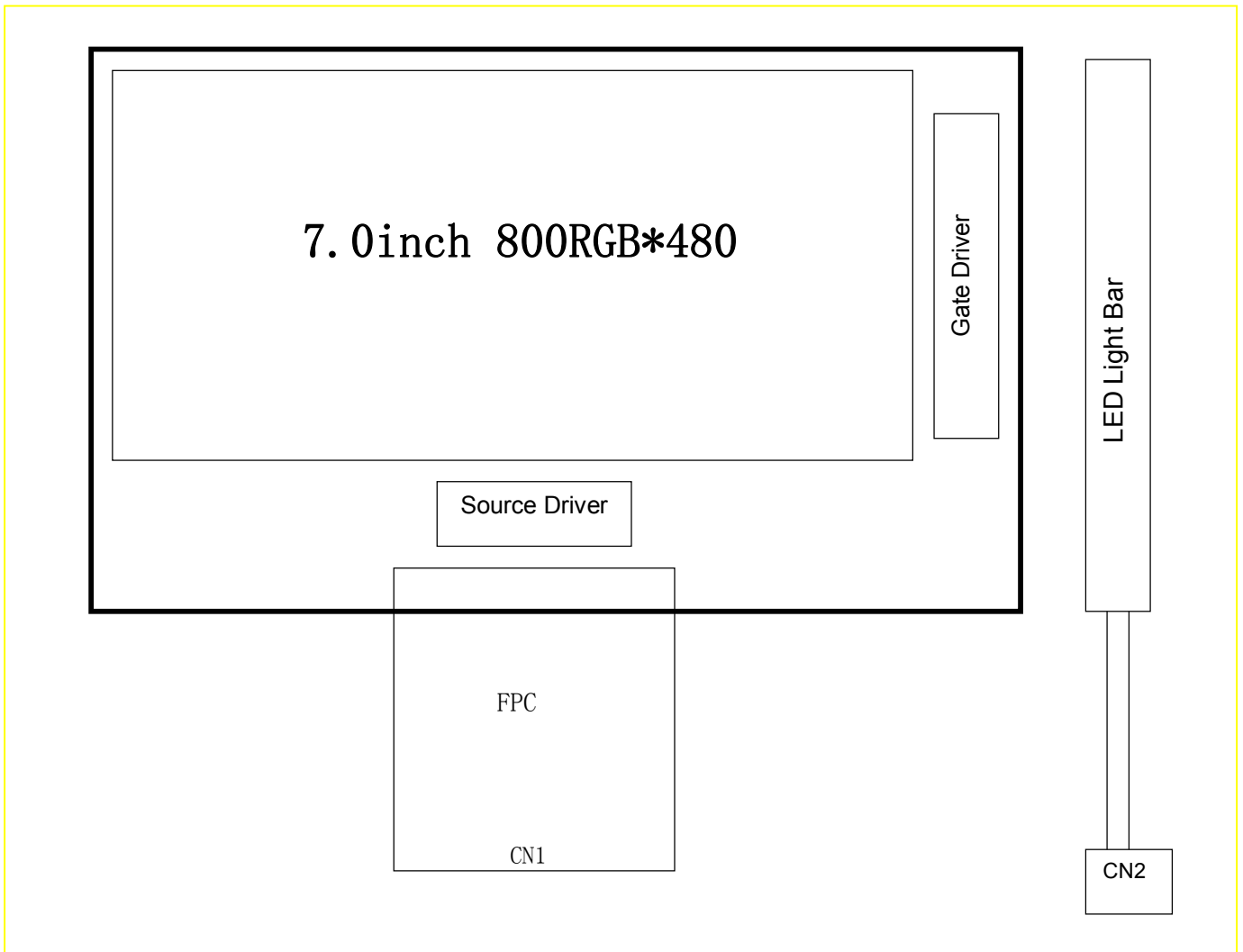



## 5 Timing Chart

### 5.1 TFT-LCD Input Timing

VCC=3.3V, AGND=GND=0V, Ta=25°C

Parameter	Symbol	Min	Typ	Max	Unit	Remark
DCLK	Fclk	-	30	40	MHZ	
	tclk	-	33.3	25.0	ns	
HSD	th	928	928	928	tclk	
	thd	800	800	800	tclk	
	thpw	1	48	-	tclk	
	thb	88	88	88	tclk	
	thfp	1	40	-	tclk	
VSD	tv	513	525	-	th	
	tvd	480	480	480	th	
	tpw	3	3	-	th	
	tvb	32	32	32	th	
	tvfp	1	13	-	th	

Note: DE timing refer to HSD, VSD input timing.



TCON Horizontal Input Timing Diagram

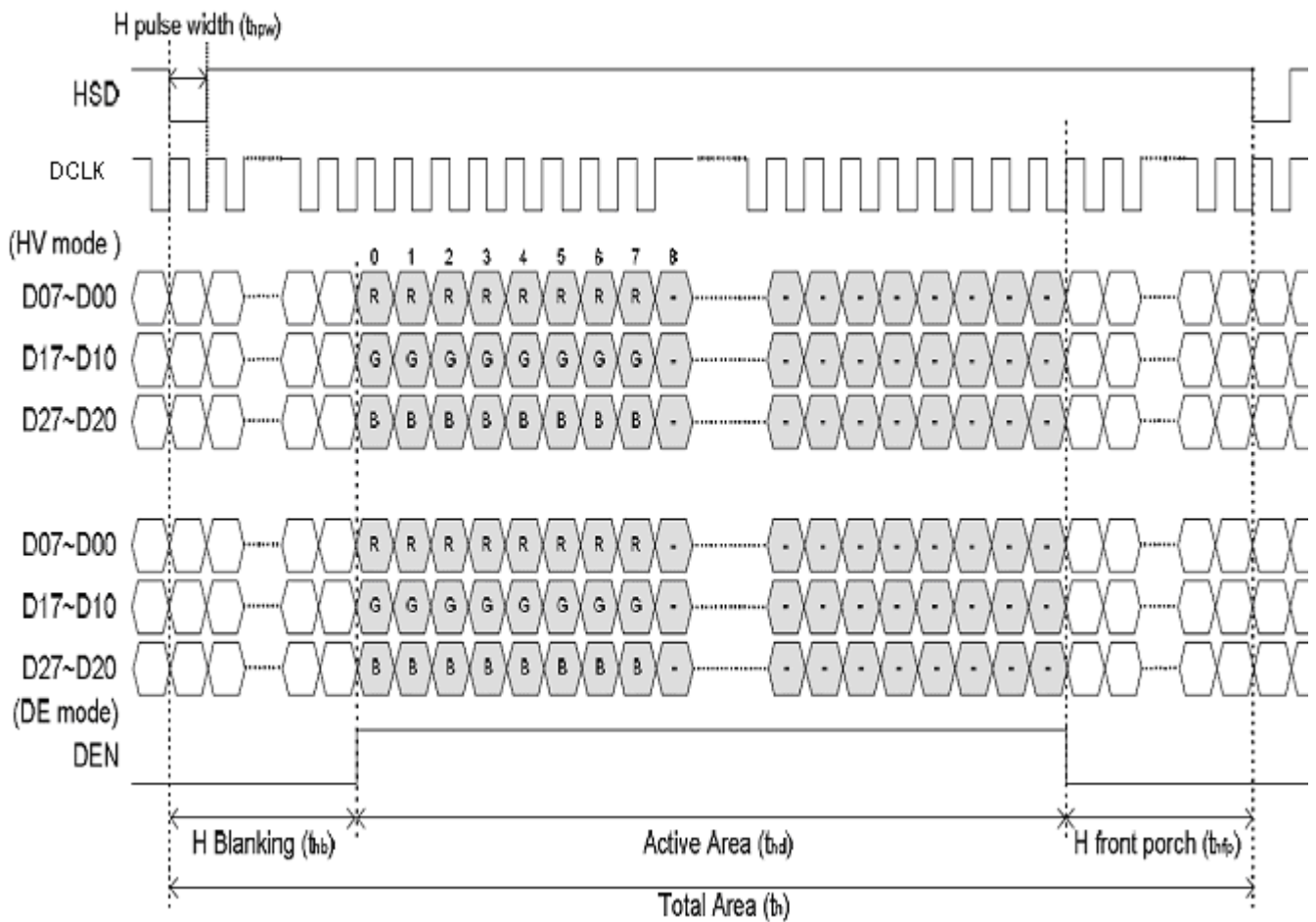

TCON Vertical Input Timing Diagram HV

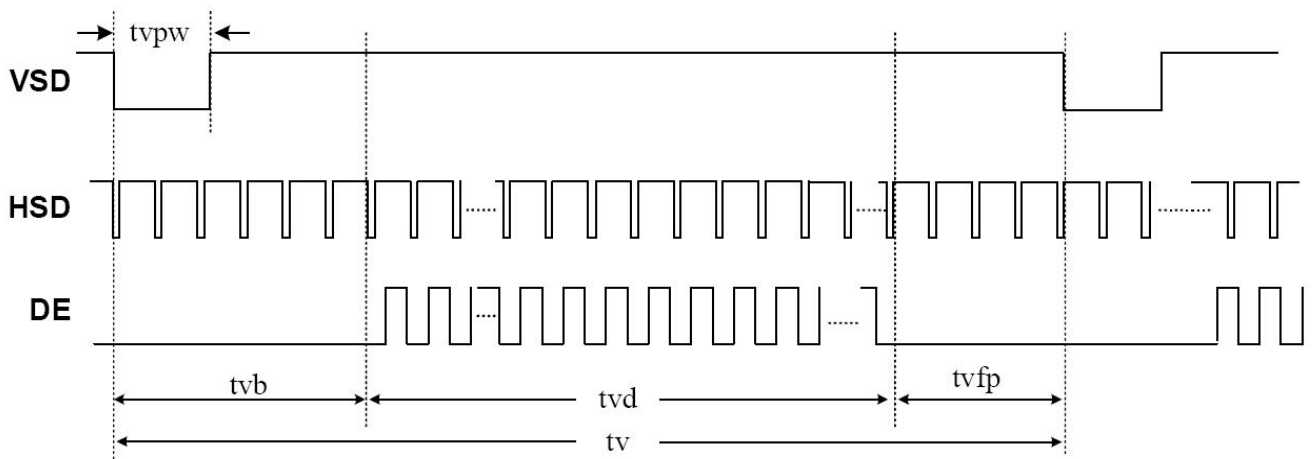



5.2 Input timing Characteristics of Interface(DCLK,VSD,HSD,DE)

(VCC=3.3V, AVSS=GND=0V, Ta=25°C)

Parameter	Symbol	Min	Typ	Max	Unit	Remark
DCLK frequency	Fclk	-	30.0	40.0	MHz	
DCLK cycle time	Tcph	-	33.3	25	ns	
DCLK pulse width	Tcw	40%	50%	60%	Tcph	
VSD setup time	Tvst	8			ns	
VSD hold time	Tvhd	8	-	-	ns	
HSD setup time	Thst	8			ns	
HSD hold time	Thhd	8	-	-	ns	
Data setup time	Tdsu	8			ns	Data to DCLK
Data hold time	Tdhd	8	-	-	ns	Data to DCLK
DE setup time	Tesu	8	-	-	ns	
DE hold time	Tehd	8	-	-	ns	

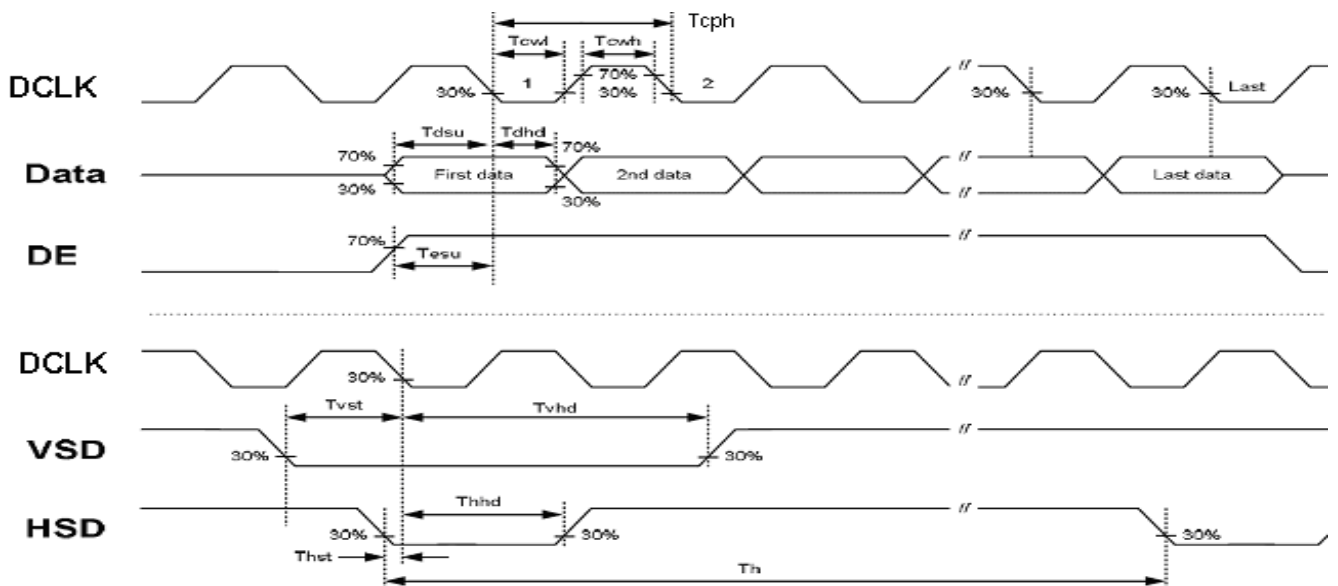



### 5.3 Enter and Exit Standby Mode Sequence

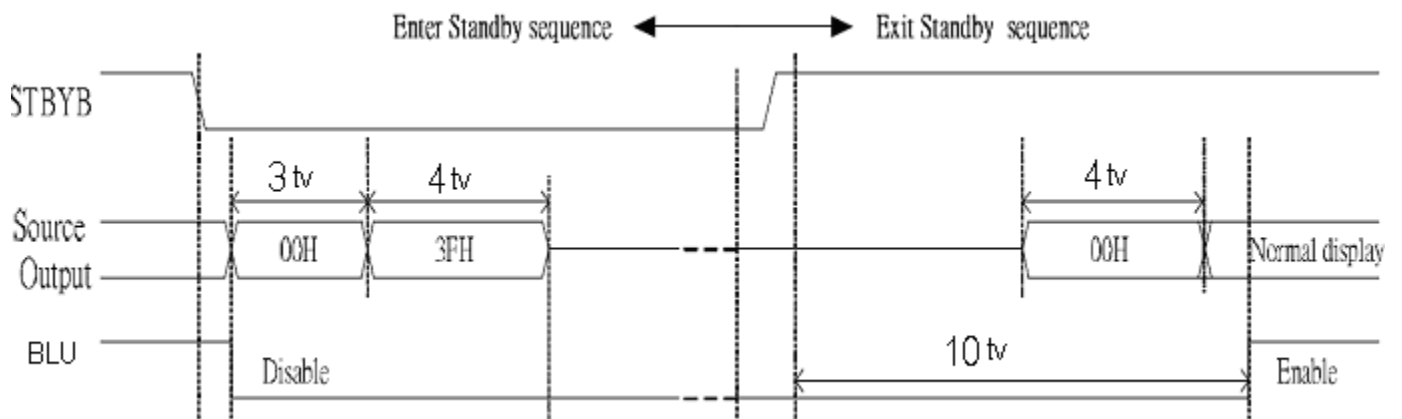

### 5.4 POWER ON/OFF SEQUENCE

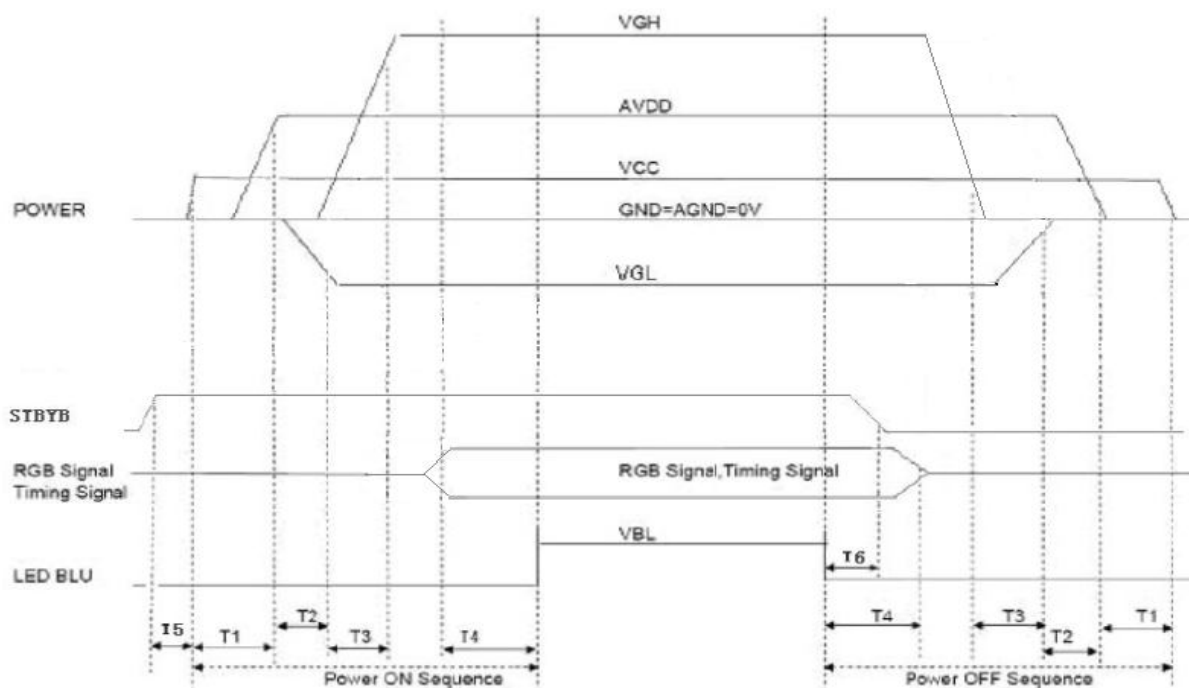

Note: T1≥20ms, T2≥20ms, T3≥5ms, T4≥100ms, T5≥5ms, T6≥5ms.





## 6 Optical Characteristics

Ta=25°C

Item	Symbol	Condition	Min	Typ	Max	Unit	Remark	
View Angles	$\theta T$	$CR \geq 10$	50	60	--	Degree	Note 2	
	$\theta B$		60	70	--			
	$\theta L$		60	70	--			
	$\theta R$		60	70	--			
Contrast Ratio	CR	$\theta=0^\circ$	400	500	--		Note1 Note3	
Response Time	$T_{ON}$	25°C	--	20	30	ms	Note1 Note4	
	$T_{OFF}$							
Chromaticity	White	Backlight is on	x	0.274	0.324	0.374		Note1 Note5
			y	0.295	0.345	0.395		
	Red		x	0.544	0.594	0.644		
			y	0.301	0.351	0.401		
	Green		x	0.299	0.349	0.399		
			y	0.531	0.581	0.631		
	Blue		x	0.102	0.152	0.202		
			y	0.053	0.103	0.153		
Uniformity	U		75	80	--	%	Note1 Note6	
NTSC			--	50	--	%	Note 5	
Luminance	L		280	350	--	cd/m <sup>2</sup>	Note1 Note7	

Test Conditions:

1.  $I_F=160\text{ mA}$ ,  $V_F=9.6\text{V}$ , and the ambient temperature is 25°C.
2. The test systems refer to Note 1 and Note 2.



Note 1: Definition of optical measurement system.

The optical characteristics should be measured in dark room. After 5 Minutes operation, the optical properties are measured at the center point of the LCD screen. All input terminals LCD panel must be ground when measuring the center area of the panel.

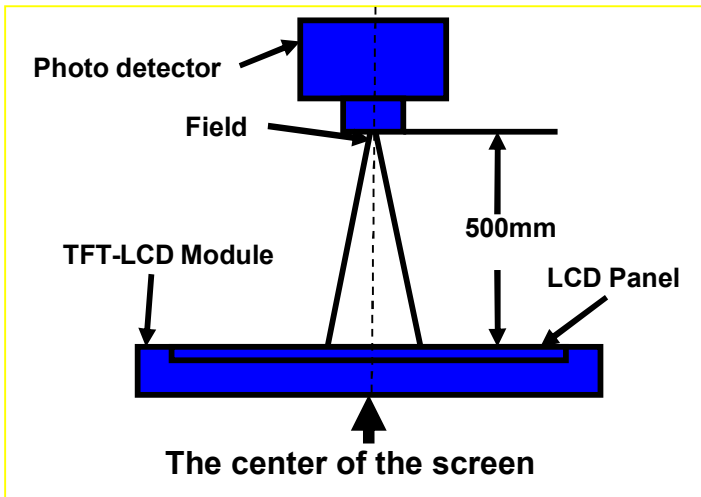

Item	Photo detector	Field
Contrast Ratio	SR-3A	1°
Luminance		
Chromaticity		
Lum Uniformity		
Response Time	BM-7A	2°

Note 2: Definition of viewing angle range and measurement system.

viewing angle is measured at the center point of the LCD by CONOSCOPE(ergo-80).

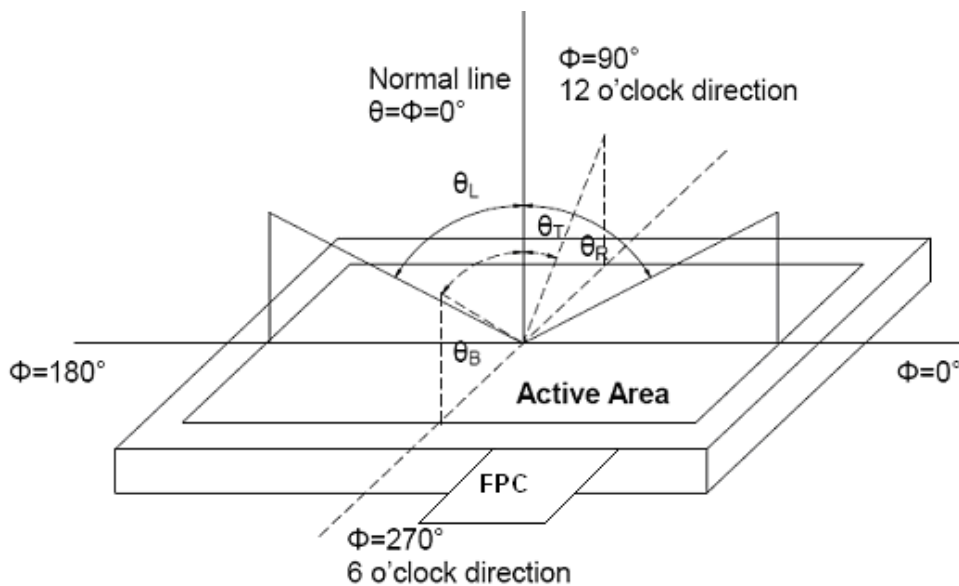

Note 3: Definition of contrast ratio

$$\text{Contrast ratio (CR)} = \frac{\text{Luminance measured when LCD is on the "White" state}}{\text{Luminance measured when LCD is on the "Black" state}}$$

“White state “: The state is that the LCD should drive by Vwhite.

“Black state”: The state is that the LCD should drive by Vblack.

Vwhite: To be determined    Vblack: To be determined.



Note 4: Definition of Response time

The response time is defined as the LCD optical switching time interval between “White” state and “Black” state. Rise time (T<sub>ON</sub>) is the time between photo detector output intensity changed from 90% to 10%. And fall time (T<sub>OFF</sub>) is the time between photo detector output intensity changed from 10% to 90%.

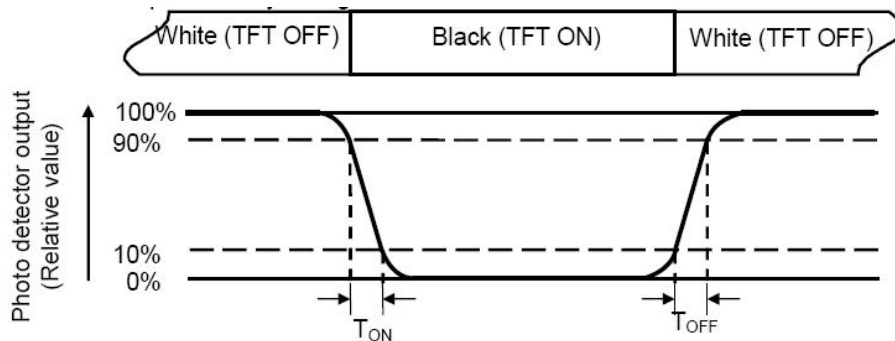

Note 5: Definition of color chromaticity (CIE1931)

Color coordinates measured at center point of LCD.

Note 6: Definition of Luminance Uniformity

Active area is divided into 9 measuring areas (Refer Fig. 2). Every measuring point is placed at the center of each measuring area.

Luminance Uniformity (U) = L<sub>min</sub>/ L<sub>max</sub>

L-----Active area length W----- Active area width

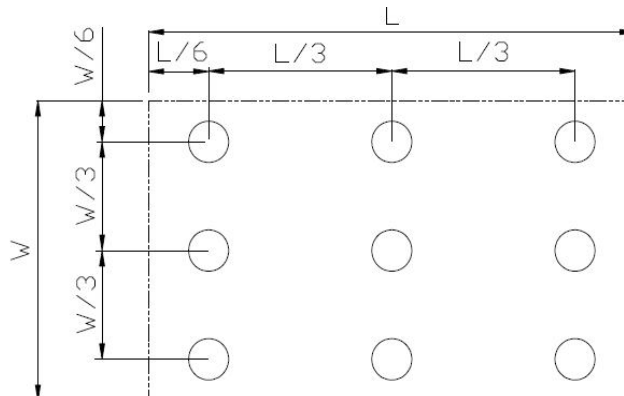

L<sub>max</sub>: The measured Maximum luminance of all measurement position.

L<sub>min</sub>: The measured Minimum luminance of all measurement position.

Note 7: Definition of Luminance:

Measure the luminance of white state at center point.

**7 Environmental / Reliability Test**

No	Test Item	Condition	Remarks
1	High Temperature Operation	Ts = +70°C, 240 hours	IEC60068-2-1 GB2423.2
2	Low Temperature Operation	Ta = -20°C, 240 hours	IEC60068-2-1 GB2423.1
3	High Temperature Storage	Ta = +80°C, 240 hours	IEC60068-2-1 GB2423.2
4	Low Temperature Storage	Ta = -30°C, 240 hours	IEC60068-2-1 GB2423.1
5	Storage at High Temperature and Humidity	Ta = +60°C, 90% RH max,240hours	IEC60068-2-78 GB/T2423.3
6	Thermal Shock (non-operation)	-30°C 30 min~+80°C 30 min, Change time:5min, 100 Cycle	Start with cold temperature, End with high temperature, IEC60068-2-14 GB2423.22
7	ESD	C=150pF,R=330Ω,5point/panel Air:±8Kv,5times; Contact:±4Kv,5times (Environment:15°C~35°C, 30%~60%.86Kpa~106Kpa)	IEC61000-4-2 GB/T17626.2
8	Vibration Test	Frequency range:10~55Hz Stroke:1.5mm Sweep:10Hz~55Hz~10Hz 2 hours for each direction of X.Y.Z. (6 hours for total)	IEC60068-2-6 GB/T2423.10
9	Mechanical Shock (Non Op)	Half Sine Wave 100G 6ms, ±X,±Y,±Z 3times for each direction	IEC60068-2-27 GB/T2423.5
10	Package Drop Test	Height:60cm, 1corner,3edges,6surfaces	IEC60068-2-34 GB/T2423.11

Note1: Ts is the temperature of panel's surface.

Note2: Ta is the ambient temperature of samples.



8 Mechanical Drawing

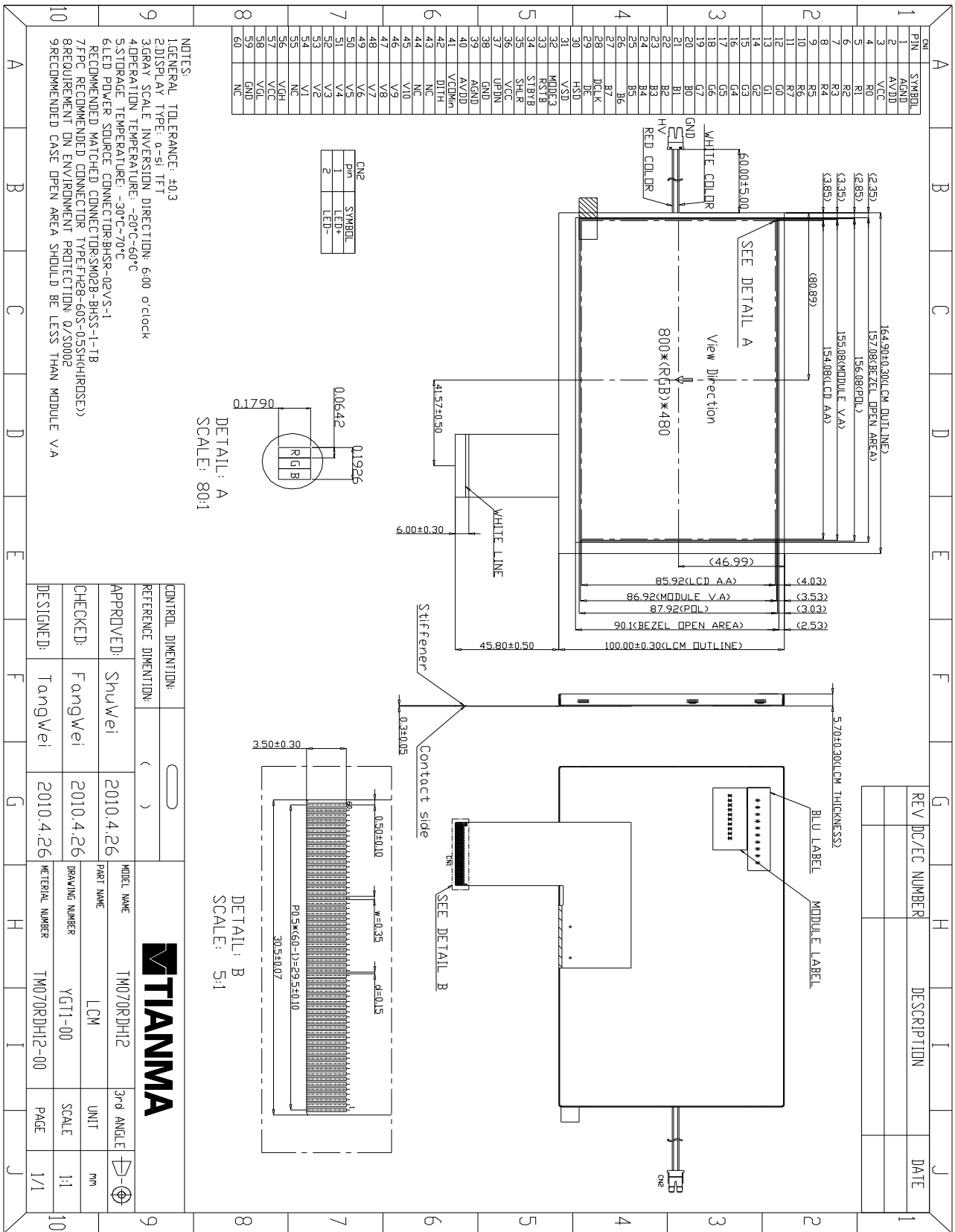

The information contained herein is the exclusive property of SHANGHAI TIANMA MICRO-ELECTRONICS Corporation, and shall not be distributed, reproduced, or disclosed in whole or in part without prior written permission of SHANGHAI TIANMA MICRO-ELECTRONICS Corporation.

**9 Packing Drawing**

No	Item	Model(Material)	Dimensions (mm)	Unit Weight ( Kg )	Quantity	Remark
1	LCM module	TM070RDH12	164.90*100.00*5.70	0.165	50	
2	Partition_1	Corrugated Paper	513*333*215	2.0	1	
3.	Anti-Static Bag	PE	160*178*0.05	0.01	50	Anti-static
4	Dust-Proof Bag	PE	700*545	0.06	1	
5	Partition_2	Corrugated Paper	505*332	0.1	2	
6	Corrugated Bar	Corrugated Paper	513*148	0.06	4	
7	Beauty-grain	Tape	30*10	0.001	150	
8	Dessicant	Dessicant	45*35	0.002	8	
9	Carton	Corrugated Paper	530*350*250	1.100	1	
10	Total weight	8.256±5%				

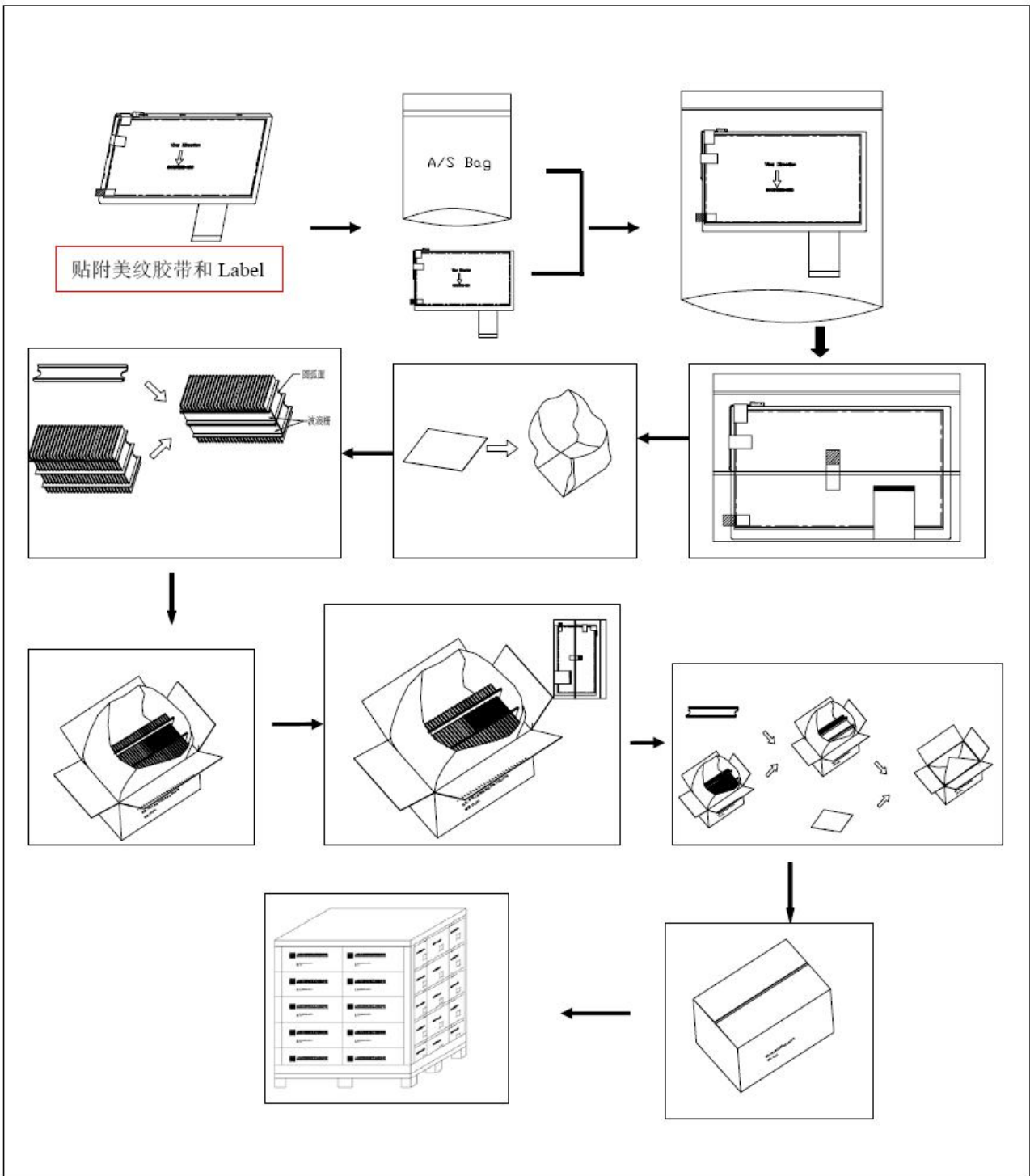



## 10 Precautions for Use of LCD Modules

### 10.1 Handling Precautions

**10.1.1** The display panel is made of glass. Do not subject it to a mechanical shock by dropping it from a high place, etc.

**10.1.2** If the display panel is damaged and the liquid crystal substance inside it leaks out, be sure not to get any in your mouth, if the substance comes into contact with your skin or clothes, promptly wash it off using soap and water.

**10.1.3** Do not apply excessive force to the display surface or the adjoining areas since this may cause the color tone to vary.

**10.1.4** The polarizer covering the display surface of the LCD module is soft and easily scratched. Handle this polarizer carefully.

**10.1.5** If the display surface is contaminated, breathe on the surface and gently wipe it with a soft dry cloth. If still not completely clear, moisten cloth with one of the following solvents:

- Isopropyl alcohol
- Ethyl alcohol

Solvents other than those mentioned above may damage the polarizer. Especially, do not use the following:

- Water
- Ketone
- Aromatic solvents

**10.1.6** Do not attempt to disassemble the LCD Module.

**10.1.7** If the logic circuit power is off, do not apply the input signals.

**10.1.8** To prevent destruction of the elements by static electricity, be careful to maintain an optimum work environment.

10.1.8.1 Be sure to ground the body when handling the LCD Modules.

10.1.8.2 Tools required for assembly, such as soldering irons, must be properly ground.

10.1.8.3 To reduce the amount of static electricity generated, do not conduct assembly and other work under dry conditions.

10.1.8.4 The LCD Module is coated with a film to protect the display surface. Be care when peeling off this protective film since static electricity may be generated.

### 10.2 Storage precautions

10.2.1 When storing the LCD modules, avoid exposure to direct sunlight or to the light of fluorescent lamps.

10.2.2 The LCD modules should be stored under the storage temperature range. If the LCD modules will be stored for a long time, the recommend condition is:

Temperature : 0°C ~ 40°C      Relatively humidity: ≤80%

10.2.3 The LCD modules should be stored in the room without acid, alkali and harmful gas.

### 10.3 Transportation Precautions

10.3.1 The LCD modules should be no falling and violent shocking during transportation, and also should avoid excessive press, water, damp and sunshine.