



MODEL NO. : TM070DDH03

ISSUED DATE: 2012-3-8

VERSION : Ver. 2.0

- Preliminary Specification
- Final Product Specification

Customer : _____

Approved by	Notes

SHANGHAI AVIC Confirmed :

Prepared by	Checked by	Approved by
Ye Chen 2012/3/8	/	Hyman Chen 2012/3/8

This technical specification is subjected to change without notice

The information contained herein is the exclusive property of SHANGHAI AVIC OPTOELECTRONICS Corporation, and shall not be distributed, reproduced, or disclosed in whole or in part without prior written permission of SHANGHAI AVIC OPTOELECTRONICS Corporation.



Table of Contents

Table of Contents.....	2
Record of Revision.....	3
1 General Specifications.....	4
2 Input/Output Terminals.....	5
3 Absolute Maximum Ratings.....	7
4 Electrical Characteristics.....	8
5 Timing Chart.....	11
6. Optical Characteristics.....	16
7. Environmental / Reliability Test.....	19
8. Mechanical Drawing.....	20
9. Packing drawing.....	21
10. Precautions for Use of LCD Modules.....	22



Record of Revision

Rev	Issued Date	Description	Editor
1.0	2011-08-05	Final Specification Release	Ye Chen
2.0	2012-3-8	Modify the VGH and VCOM	Ye Chen

The information contained herein is the exclusive property of SHANGHAI AVIC OPTOELECTRONICS Corporation, and shall not be distributed, reproduced, or disclosed in whole or in part without prior written permission of SHANGHAI AVIC OPTOELECTRONICS Corporation.



1 General Specifications

Feature		Spec
Display Spec.	Size	7.0 inch
	Resolution	1024 RGB (H)×600(V)
	Interface	LVDS 40 Pin
	Color Depth	16.7 M
	Technology Type	a-si TFT
	Pixel Pitch (mm)	0.150×0.150
	Pixel Configuration	RGB stripe
	Display Mode	Normally White
	Surface Treatment(Up Polarizer)	Anti-Glare
	Viewing Direction	12 o'clock
	Gray Scale Inversion Direction	6 o'clock
Mechanical Characteristics	LCM (W x H x D) (mm)	165.75 (W) ×105.39(H)×3.40(D)
	Active Area(mm)	153.6(H)×90.0(V)
	With /Without TSP	Without TSP
	Weight (g)	112g
	LED Numbers	18 LEDS

Note 1: Viewing direction for best image quality is different from TFT definition. There is a 180 degree shift.

Note 2: Requirements on Environmental Protection: RoHS

Note 3: LCM weight tolerance: +/- 5%



2 Input/Output Terminals

2.1 CN1 of FPC

Pin No.	Symbol	I/O	function	Remarks
1	VCOM	P	Common Voltage	
2	VDD	P	Power Voltage for digital circuit	
3	VDD	P	Power Voltage for digital circuit	
4	NC	---	No connection	
5	Reset	I	Global reset pin	Active Low to enter Reset State
6	STBYB	I	Standby mode, Normally pulled high	STBYB="1", Normally operation STBYB="0", Timing controller, source driver will turn off, all output are High-Z
7	GND	P	Ground	
8	RXIN0-	I	- LVDS differential data input	
9	RXIN0+	I	+LVDS differential data input	
10	GND	P	Ground	
11	RXIN1-	I	-LVDS differential data input	
12	RXIN1+	I	+LVDS differential data input	
13	GND	P	Ground	
14	RXIN2-	I	-LVDS differential data input	
15	RXIN2+	I	+LVDS differential data input	
16	GND	P	Ground	
17	RXCLKIN-	I	-LVDS differential clock input	
18	RXCLKIN+	I	+LVDS differential clock input	
19	GND	P	Ground	
20	RXIN3-	I	-LVDS differential data input	
21	RXIN3+	I	+LVDS differential data input	
22	GND	P	Ground	
23	NC	---	No connection	
24	NC	---	No connection	
25	GND	P	Ground	
26	NC	---	No connection	
27	DIMO	O	Backlight CABG controller signal output	Normally Pull High
28	SELB	I	6bit/8bit mode select	Note 2
29	AVDD	P	Power for Analog Circuit	
30	GND	P	Ground	
31	LED-	P	LED Cathode	
32	LED-	P	LED Cathode	
33	L/R	P	Horizontal inversion	L/R=1, from left to right; L/R=0, from right to left
34	U/D	P	Vertical inversion	U/D=0, from up to down; U/D=1, from down to up.
35	VGL	---	Gate OFF Voltage	
36	CABCEN1	---	CABC H/W enable	Note 3

The information contained herein is the exclusive property of SHANGHAI AVIC OPTOELECTRONICS Corporation, and shall not be distributed, reproduced, or disclosed in whole or in part without prior written permission of SHANGHAI AVIC OPTOELECTRONICS Corporation.



37	CABCEN2	P	CABC H/W enable	Note 3
38	VGH	P	Gate ON Voltage	
39	LED+	P	LED Anode	
40	LED+	P	LED Anode	

Note 1: I/O definition.

I---Input pin, O---Output pin, P--- Power/Ground, N--- No Connection

Note2: If LVDS input data is 6 bits ,SELB must be set to High;
If LVDS input data is 8 bits ,SELB must be set to Low.

Note3: When CABC_EN="00", CABC OFF.
When CABC_EN="01", user interface image.
When CABC_EN="10", still picture.
When CABC_EN="11", moving image.
When CABC off, don't connect DIMO, else connect it to backlight.

2.2 U/D R/L Function Description

Scan Control Input		Scanning Direction
UPDN	SHLR	
GND	VDD	Up to Down, Left to Right
VDD	GND	Down to Up, Right to Left
GND	GND	Up to Down, Right to Left
VDD	VDD	Down to Up, Left to Right



3 Absolute Maximum Ratings

AGND= GND=0V, Ta = 25°C

Item	Symbol	Min	Max	Unit	Remark
Power Voltage	VDD	-0.3	5.0	V	
	AVDD	6.5	13.5	V	
	VGH	-0.3	20.0	V	
	VGL	-20.0	0.3	V	
Backlight Forward Current	I _{LED}	-	25	mA	For each LED
Operating Temperature	T _{OPR}	-20	70	°C	
Storage Temperature	T _{STG}	-30	80	°C	



4 Electrical Characteristics

4.1 Recommended Operating Condition

AGND=GND=0V, Ta = 25°C

Item	Symbol	Min	Typ	Max	Unit	Remark
Digital Supply Voltage	VDD	3.0	3.3	3.6	V	
Analog Supply Voltage	AVDD	10.8	11.0	11.2	V	
Gate On Voltage	VGH	15.7	16.0	16.3	V	
Gate Off Voltage	VGL	-7.1	-6.8	-6.5	V	
Common Electrode Driving Signal	VCOM	3.45	3.55	3.65	V	With the VR Knob

Note: The value is for design stage only.



4.2 Recommended Driving Condition for Backlight

Ta=25°C

Item	Symbol	Min	Typ	Max	Unit	Remark
Forward Current	I _F	-	120	-	mA	18 LEDs (3 LED Serial, 6 LED Parallel)
Forward Voltage	V _F	-	9.3	-	V	
Operating Life Time	-	15000	-	-	Hrs	

Note1: The LED driving condition is defined for each LED module (3 LED Serial, 6 LED Parallel). For each LED: I_F (1/6) =20mA, V_F (1/3) =3.3V.

Note2: Under LCM operating, the stable forward current should be inputted. And forward voltage is for reference only.

Note3: I_F is defined for one channel LED. Optical performance should be evaluated at Ta=25°C only. If LED is driven by high current, high ambient temperature & humidity condition. The life time of LED will be reduced. Operating life means brightness goes down to 50% initial brightness. Typical operating life time is estimated data.

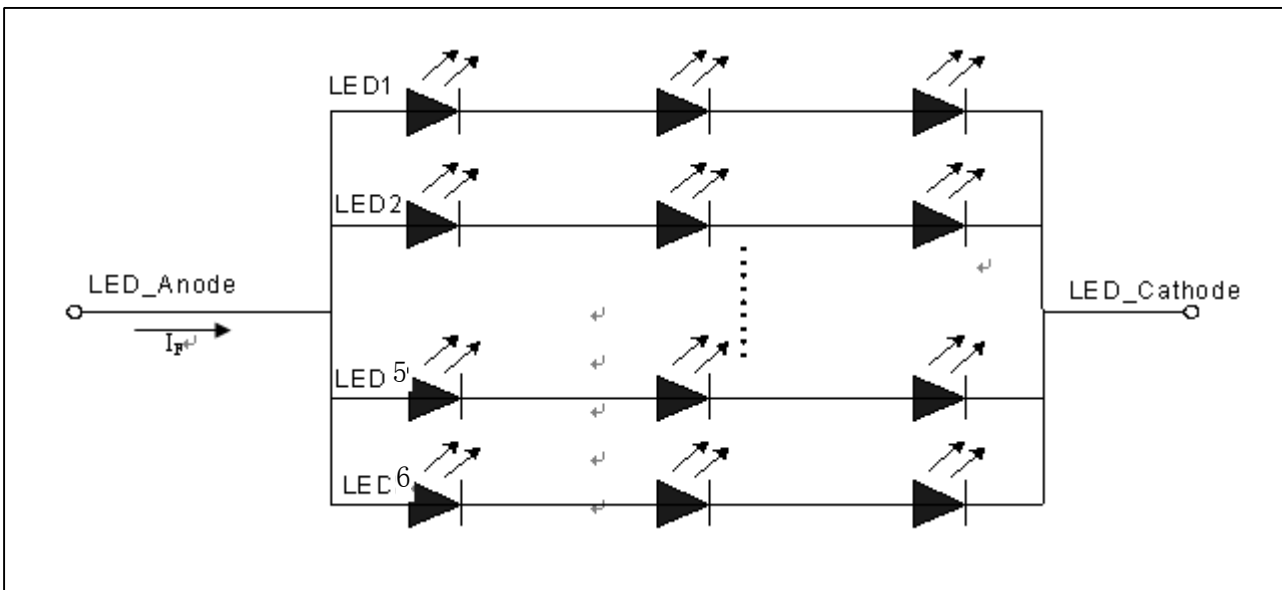

Note4: The LED driving condition is defined for each LED module.



4.3 Power Consumption

AGND=GND=0V, Ta = 25°C

Item	Symbol	Condition	Min	Typ	Max	Unit	Remark
Digital Supply Current	I _{VDD}	VDD=3.3 V	-	16	21	mA	
Analog Supply Current	I _{AVDD}	AVDD=11.0 V	-	33	50	mA	
Gate On Current	I _{VGH}	VGH=16.0 V	-	0.4	1	mA	
Gate Off Current	I _{VGL}	VGL=-6.8 V	-	0.4	1	mA	
Power Consumption	Panel&Gamma		-	426.5	646.1	mW	
	Backlight		-	1188		W	
	Total		-	1614.5		W	

4.4 Block Diagram

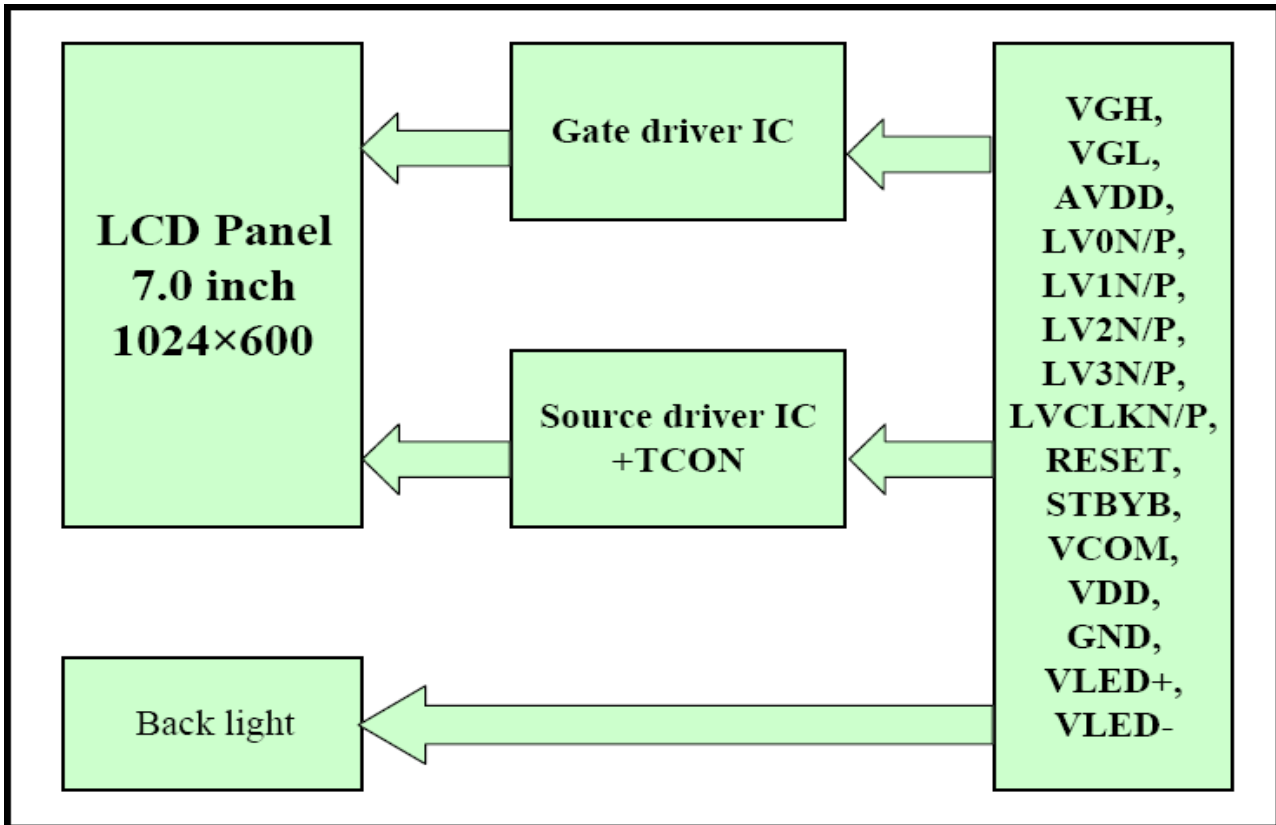



5 Timing Chart

5.1 AC Electrical Characteristics

Parameter	Symbol	Min	Typ	Max	Unit	Conditions
Clock Frequency	R_{xFCLK}	40.8	51.2	71	MHz	
Input data skew margin	T_{RSKM}	500	-	-	ps	
Clock high time	T_{LVCH}	-	$4/(7 * R_{xFCLK})$	-	ns	
Clock low time	T_{LVCL}	-	$3/(7 * R_{xFCLK})$	-	ns	
PLL wake-up time	T_{enPLL}	-	-	150	us	

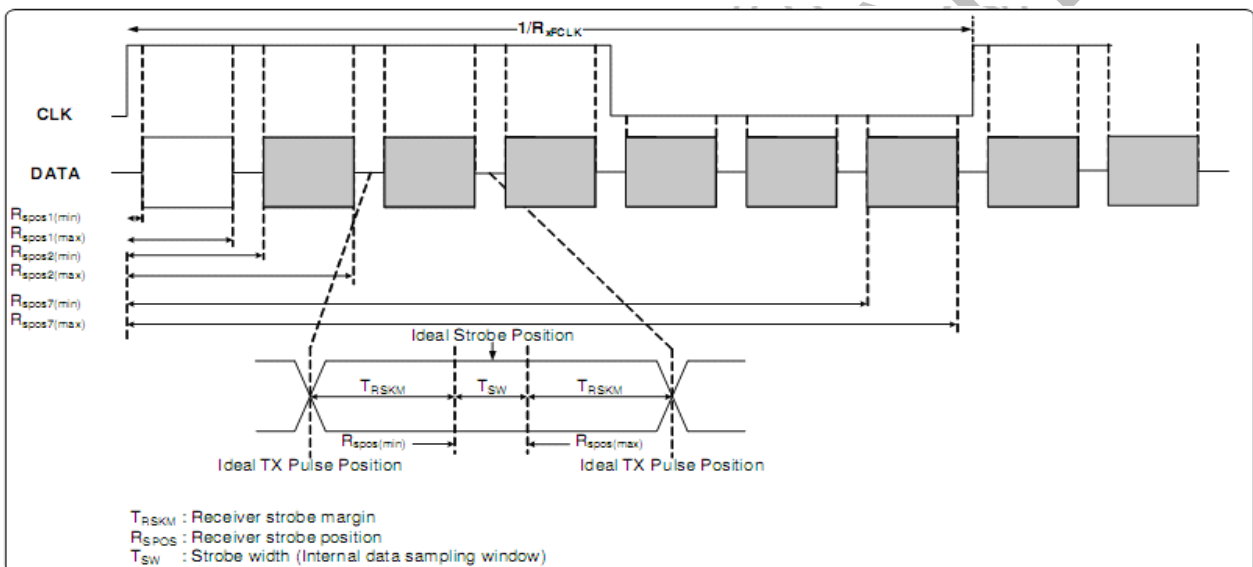
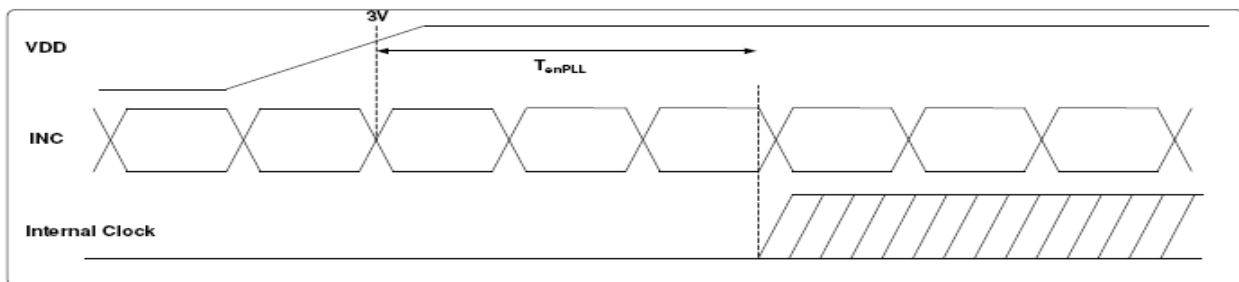
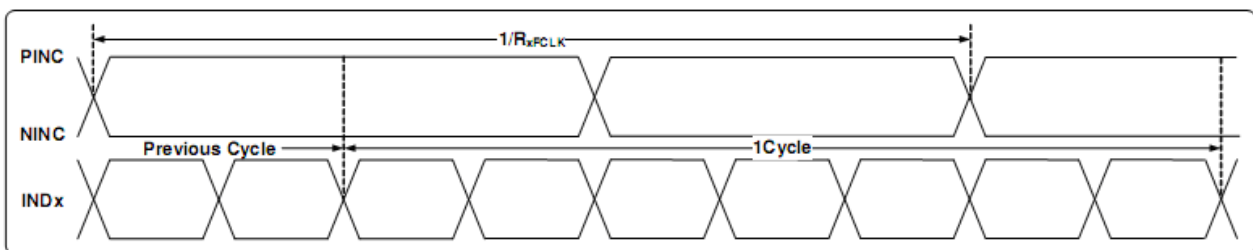

The information contained herein is the exclusive property of SHANGHAI AVIC OPTOELECTRONICS Corporation, and shall not be distributed, reproduced, or disclosed in whole or in part without prior written permission of SHANGHAI AVIC OPTOELECTRONICS Corporation.



5.2 DC Electrical Characteristics

VDD=3.3V, AVDD=11V, AGND=GND=0V, Ta=25°C

Parameter	Symbol	Min	Typ	Max	Unit	Remark
Differential input high Threshold voltage	R_{XVTH}	-	-	+0.1	V	
Differential input Low Threshold voltage	R_{XVTL}	-0.1	-	-	V	
Input voltage range	R_{XVIN}	0	-	$VDD-1.2+ V_{ID} /2$	V	
Differential input common Mode voltage	R_{XVCM}	$ V_{ID} /2$	-	$VDD-1.2$	V	
Differential input voltage	$ V_{ID} $	0.2	v	0.6	V	
Differential input leakage Current	$R_{V_{Xliz}}$	-10	v	+10	uA	
LVDS Digital Operating Current	I_{ddlvds}	-	(15)	(30)	mA	Fclk=65MHz, VDD=3.3V
LVDS Digital Stand-by Current	I_{stlvds}	-	(10)	(50)	uA	Clock & all functions are stopped

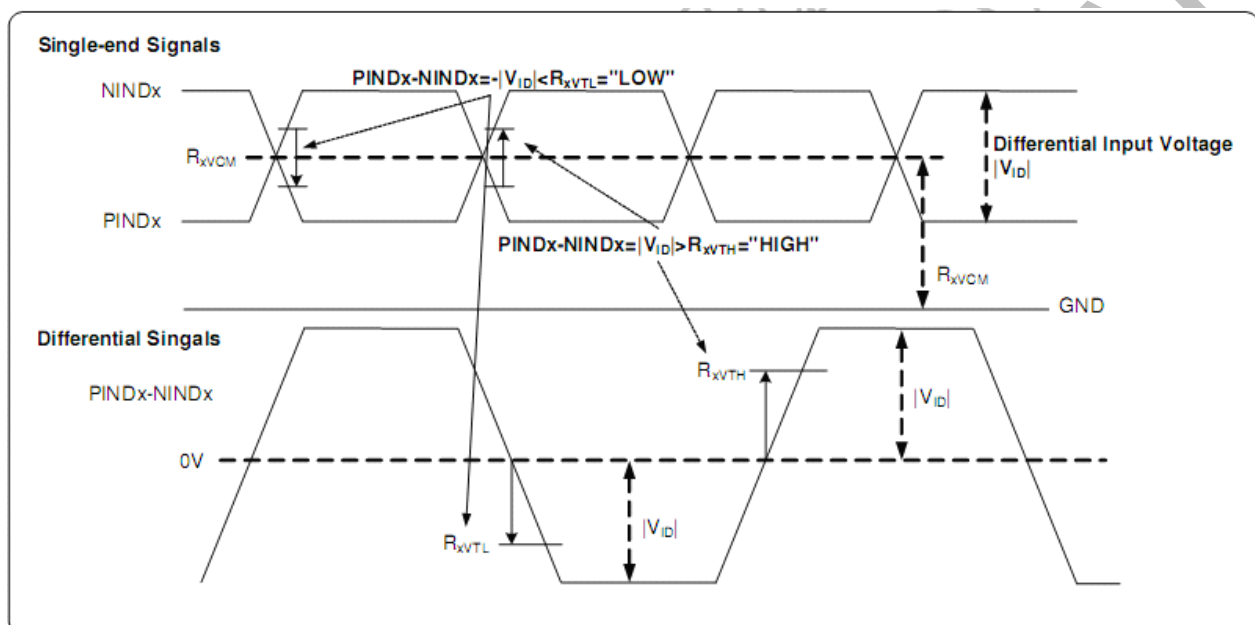

The information contained herein is the exclusive property of SHANGHAI AVIC OPTOELECTRONICS Corporation, and shall not be distributed, reproduced, or disclosed in whole or in part without prior written permission of SHANGHAI AVIC OPTOELECTRONICS Corporation.



5.3 Timing

Parameter	Symbol	Min	Typ	Max	Unit	Remark
Clock frequency	fclk	40.8	51.2	67.2	MHz	Frame rate=60Hz
Horizontal display area	thd	1024			DCLK	
HS period time	th	1114	1344	1400	DCLK	
HS Blanking	thbp+thfp	90	320	376	DCLK	
Vertical display area	tvd	600			H	
VS period time	tv	610	635	800	H	
VS Blanking	tvbp+tvfp	10	35	200	H	

5.4 Data Input Format

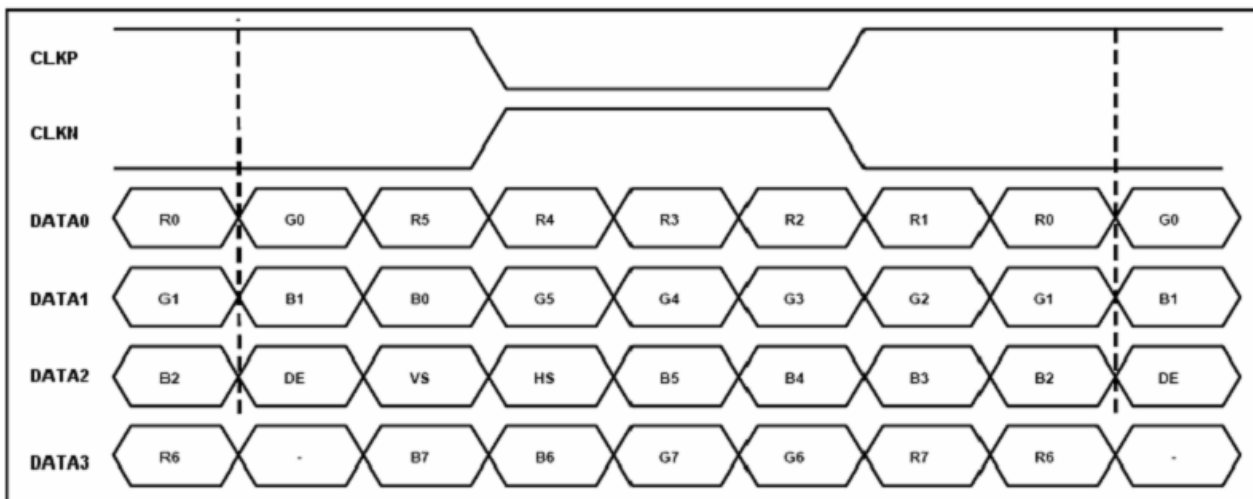

5.5 Input Clock and Data Timing Diagram

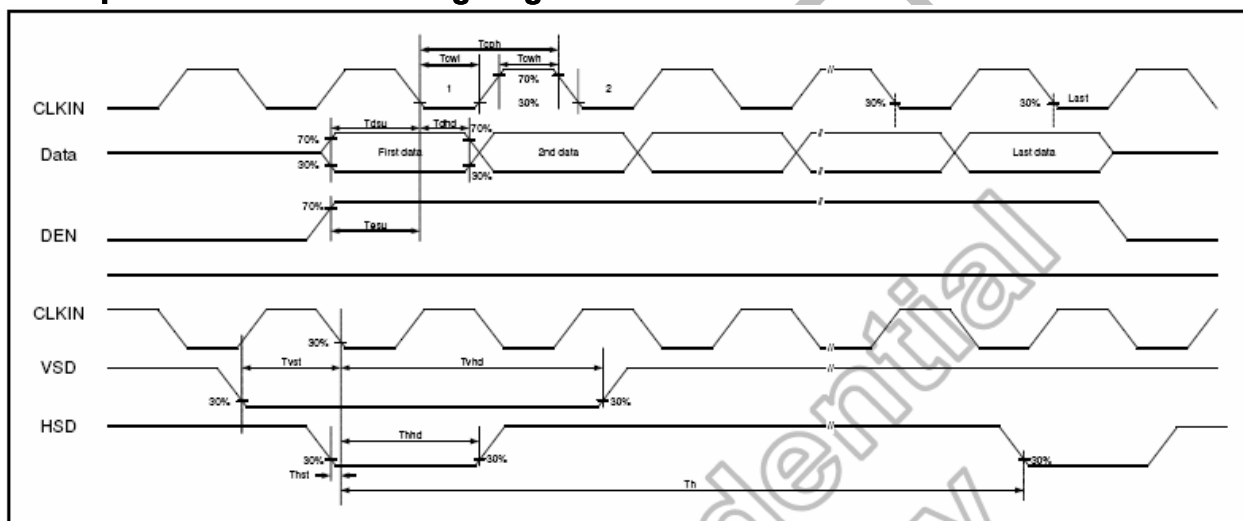

The information contained herein is the exclusive property of SHANGHAI AVIC OPTOELECTRONICS Corporation, and shall not be distributed, reproduced, or disclosed in whole or in part without prior written permission of SHANGHAI AVIC OPTOELECTRONICS Corporation.



5.6 POWER ON/OFF SEQUENCE

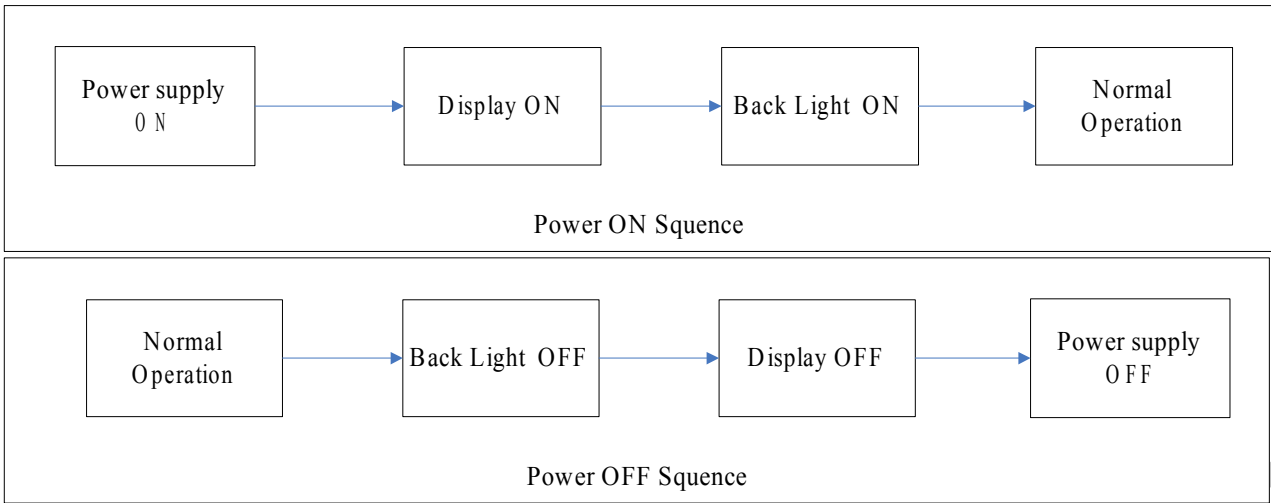
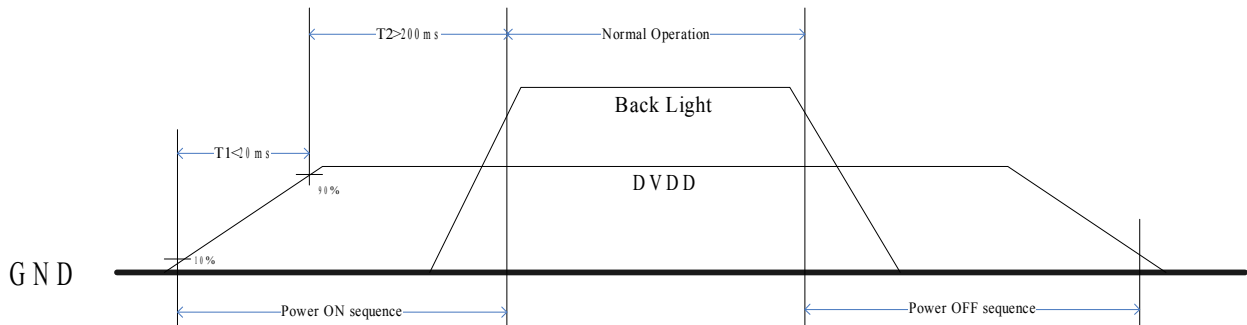



5.7 System power ON/OFF sequence

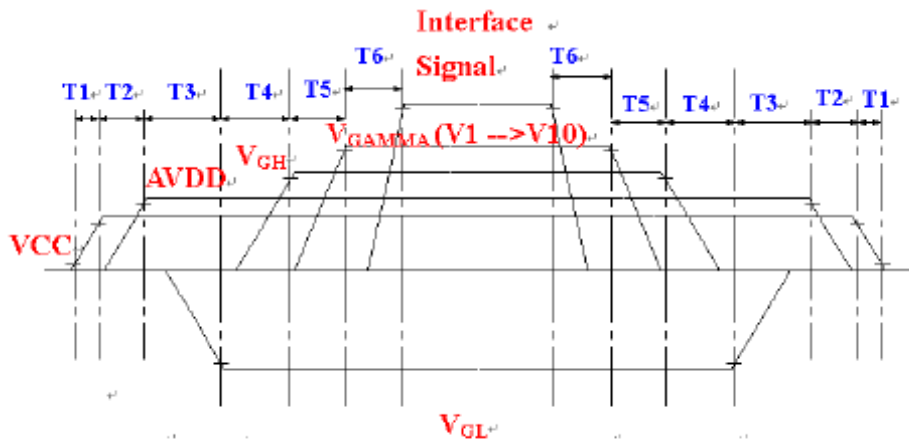

	Min.	Typ.	Max.	Unit
T1	-	-	20	ms
T2	16	-	-	ms
T3	> 0			ms
T4	> 0			ms
T5	> 0			ms
T6	> 0			ms



6. Optical Characteristics

Ta=25°C

Item	Symbol	Condition	Min	Typ	Max	Unit	Remark	
View Angles	θT	$CR \geq 10$	60	70	-	Degree	Note 2	
	θB		65	75	-			
	θL		65	75	-			
	θR		65	75	-			
Contrast Ratio	CR	$\theta=0^\circ$	400	500	-		Note1 Note3	
Response Time	T_{ON}	25°C	-	20	30	ms	Note1	
	T_{OFF}						Note4	
Chromaticity	White	Backlight is on	x	0.260	0.310	0.360		Note1 Note5
			y	0.280	0.330	0.380		
	Red		x	0.539	0.589	0.639		
			y	0.298	0.348	0.398		
	Green		x	0.291	0.341	0.391		
			y	0.533	0.583	0.633		
	Blue		x	0.102	0.152	0.202		
			y	0.057	0.107	0.157		
Uniformity	U		70	75	-	%	Note1 Note6	
NTSC			45	50	-	%	Note 5	
Luminance	L		280	320	-	cd/m ²	Note1 Note7	

Test Conditions:

1. $I_F=20\text{ mA}$, $V_F=9.9\text{ V}$ and the ambient temperature is 25°C.
2. The test systems refer to Note 1 and Note 2.



Note 1: Definition of optical measurement system.

The optical characteristics should be measured in dark room. After 5 Minutes operation, the optical properties are measured at the center point of the LCD screen. All input terminals LCD panel must be ground when measuring the center area of the panel.

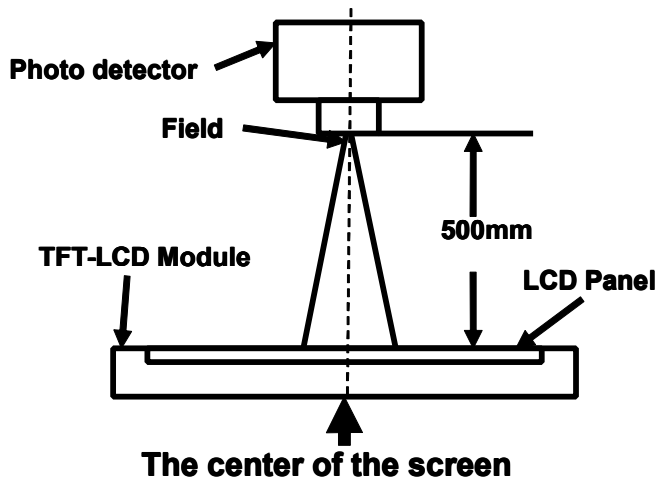

Item	Photo detector	Field
Contrast Ratio	BM-5A	1°
Luminance		
Lum Uniformity		
Chromaticity	SR-3A	
Response Time	TRD100	-

Note 2: Definition of viewing angle range and measurement system.

viewing angle is measured at the center point of the LCD by CONOSCOPE(ergo-80).

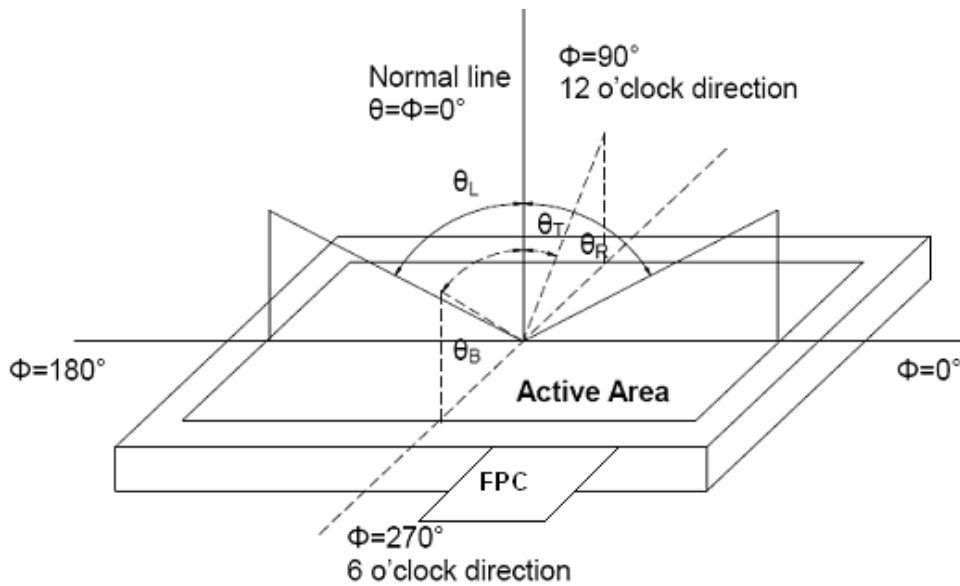

Note 3: Definition of contrast ratio

$$\text{Contrast ratio (CR)} = \frac{\text{Luminance measured when LCD is on the "White" state}}{\text{Luminance measured when LCD is on the "Black" state}}$$

“White state “: The state is that the LCD should drive by V_{white} .

“Black state”: The state is that the LCD should drive by V_{black} .

V_{white} : To be determined V_{black} : To be determined.



Note 4: Definition of Response time

The response time is defined as the LCD optical switching time interval between “White” state and “Black” state. Rise time (TON) is the time between photo detector output intensity changed from 90% to 10%. And fall time (TOFF) is the time between photo detector output intensity changed from 10% to 90%.

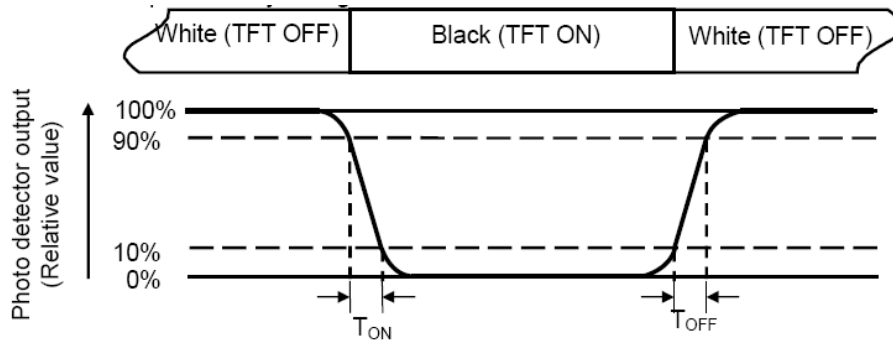

Note 5: Definition of color chromaticity (CIE1931)

Color coordinates measured at center point of LCD.

Note 6: Definition of Luminance Uniformity

Active area is divided into 9 measuring areas (Refer Fig. 2). Every measuring point is placed at the center of each measuring area.

Luminance Uniformity (U) = Lmin/ Lmax

L-----Active area length W----- Active area width

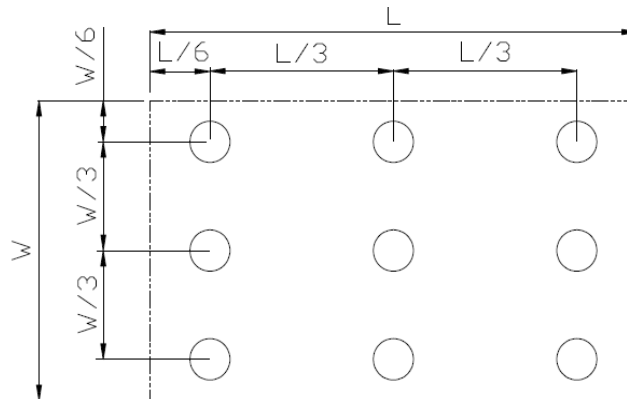

Lmax: The measured Maximum luminance of all measurement position.

Lmin: The measured Minimum luminance of all measurement position.

Note 7: Definition of Luminance:

Measure the luminance of white state at center point.

**7. Environmental / Reliability Test**

No	Test Item	Condition	Remarks
1	High Temperature Operation	Ts = +70°C, 240 hours	IEC60068-2-1:2007 GB2423.2-2008
2	Low Temperature Operation	Ta = -20°C, 240 hours	IEC60068-2-1:2007 GB2423.1-2008
3	High Temperature Storage	Ta = +80°C, 240 hours	IEC60068-2-1:2007 GB2423.2-2008
4	Low Temperature Storage	Ta = -30°C, 240 hours	IEC60068-2-1:2007 GB2423.1-2008
5	Storage at High Temperature and Humidity	Ta = +60°C, 90% RH max,240hours	IEC60068-2-78 :2001 GB/T2423.3—2006
6	Thermal Shock (non-operation)	-30°C 30 min~+80°C 30 min, Change time:5min, 20 Cycle	Start with cold temperature, End with high temperature, IEC60068-2-14:1984,G B2423.22-2002
7	ESD	C=150pF,R=330Ω,5point/panel Air:±8Kv,5times; Contact:±4Kv,5times (Environment:15°C~35°C, 30%~60%.86Kpa~106Kpa)	IEC61000-4-2:2001 GB/T17626.2-2006
8	Vibration Test	Frequency range:10~55Hz Stroke:1.5mm Sweep:10Hz~55Hz~10Hz 2 hours for each direction of X.Y.Z. (6 hours for total)	IEC60068-2-6:1982 GB/T2423.10—1995
9	Mechanical Shock (Non Op)	Half Sine Wave 60G 6ms, ±X,±Y,±Z 3times for each direction	IEC60068-2-27:1987 GB/T2423.5—1995
10	Package Drop Test	Height:60cm, 1corner,3edges,6surfaces	IEC60068-2-32:1990 GB/T2423.8—1995

Note1: Ts is the temperature of panel's surface.

Note2: Ta is the ambient temperature of samples.

Note3: In the standard condition,there is not display function NG issue occurred.All the cosmetic specification is judged before the reliability stress.



8. Mechanical Drawing

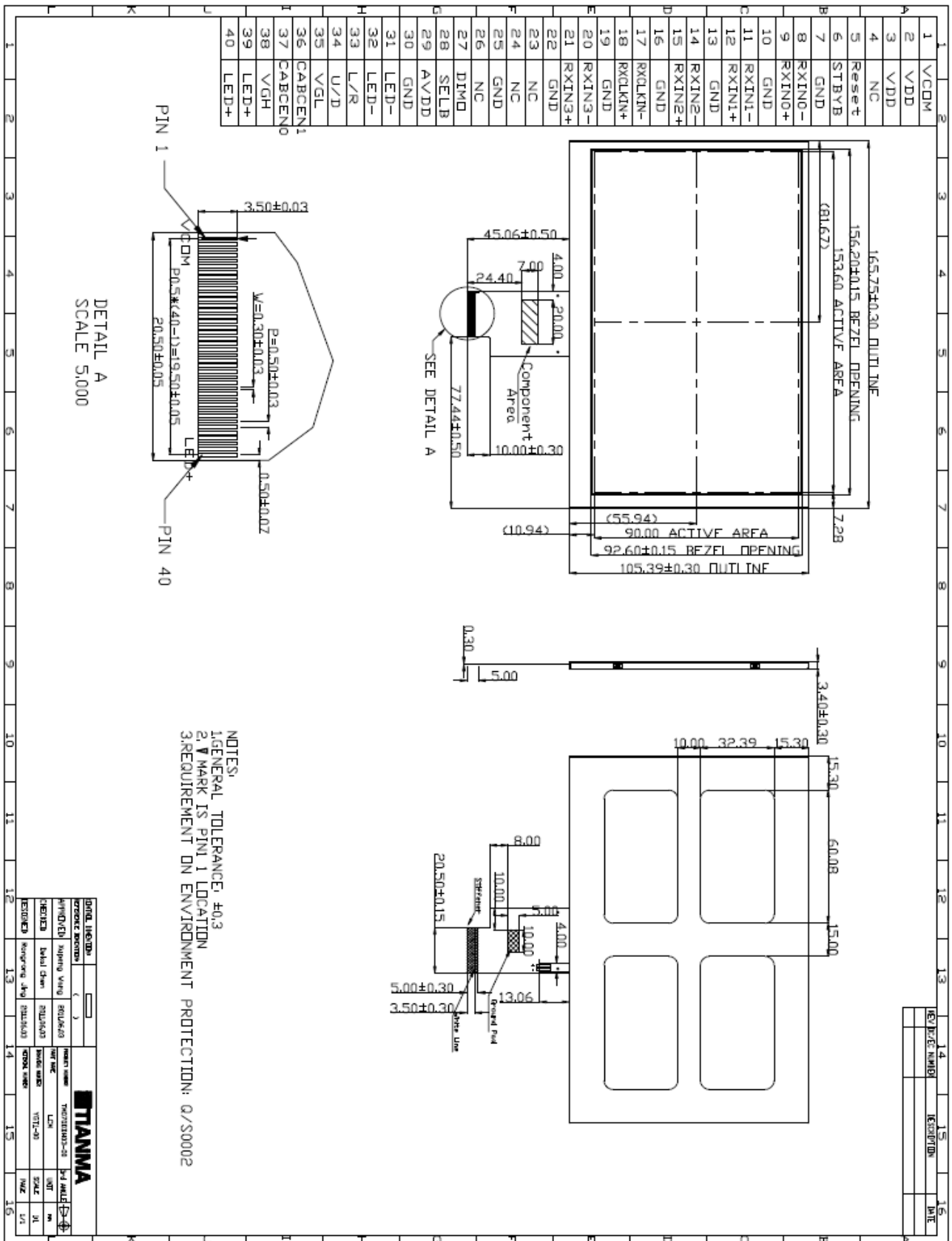

The information contained herein is the exclusive property of SHANGHAI AVIC OPTOELECTRONICS Corporation, and shall not be distributed, reproduced, or disclosed in whole or in part without prior written permission of SHANGHAI AVIC OPTOELECTRONICS Corporation.



9. Packing drawing

NO	Item	Model (material)	Dimensions(mm)	Unit Weight(Kg)	Quantity	Remark
1	LCM Module	TM070DDH03	165.75×105.39×3.40	0.112	50	
2	Partition_1	Corrugated paper	513×333×215	1.571	1	
3	Anti-static Bag	PE	180×160×0.05	0.001	50	Anti-static
4	Dust-Proof Bag	PE	700×530	0.06	1	
5	Partition_2	Corrugated Paper	505×332×4.0	0.098	2	
6	Corrugated Bar	Corrugated Paper	513×146×19.5	0.057	4	
7	Carton	Corrugated Paper	530×350×250	1.12	1	
8	Model Label		35×15	0.001	1	
9	Total Weight	8.826±5%				

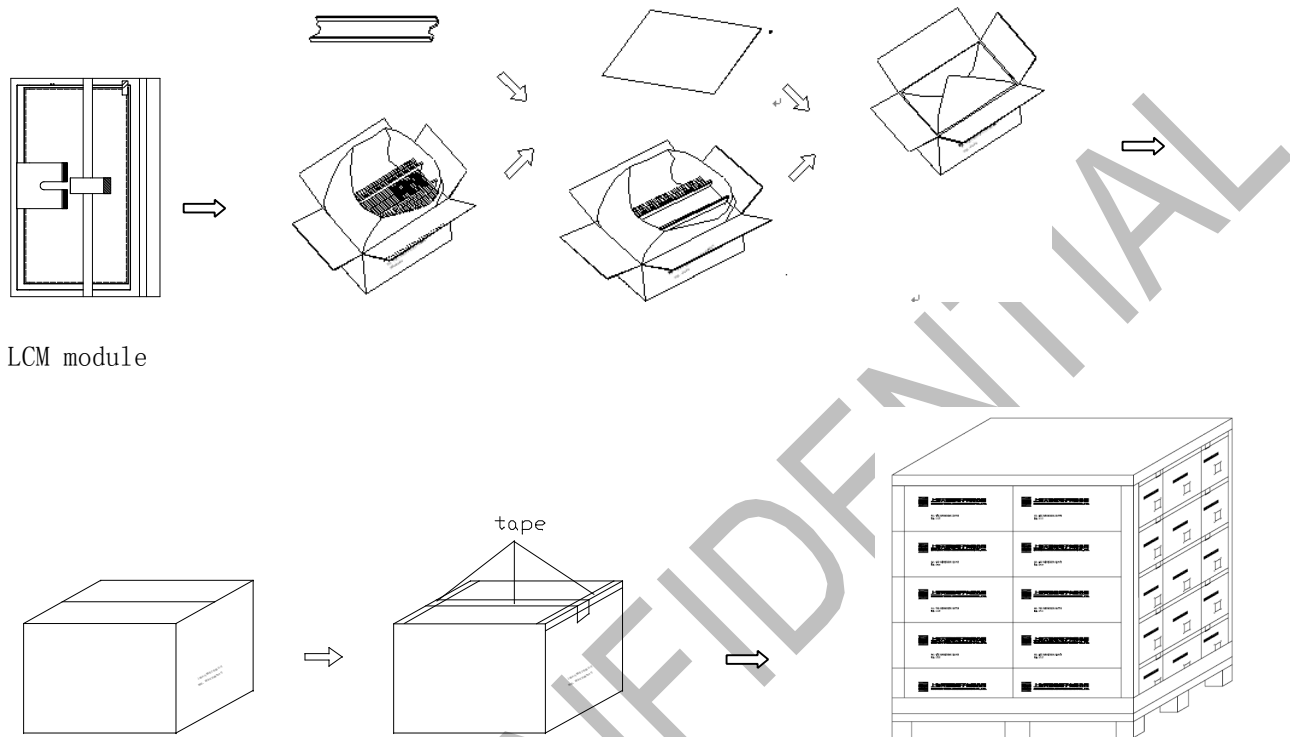



10. Precautions for Use of LCD Modules

10.1 Handling Precautions

10.1.1 The display panel is made of glass. Do not subject it to a mechanical shock by dropping it from a high place, etc.

10.1.2 If the display panel is damaged and the liquid crystal substance inside it leaks out, be sure not to get any in your mouth, if the substance comes into contact with your skin or clothes, promptly wash it off using soap and water.

10.1.3 Do not apply excessive force to the display surface or the adjoining areas since this may cause the color tone to vary.

10.1.4 The polarizer covering the display surface of the LCD module is soft and easily scratched. Handle this polarizer carefully.

10.1.5 If the display surface is contaminated, breathe on the surface and gently wipe it with a soft dry cloth. If still not completely clear, moisten cloth with one of the following solvents:

- Isopropyl alcohol
- Ethyl alcohol

Solvents other than those mentioned above may damage the polarizer. Especially, do not use the following:

- Water
- Ketone
- Aromatic solvents

10.1.6 Do not attempt to disassemble the LCD Module.

10.1.7 If the logic circuit power is off, do not apply the input signals.

10.1.8 To prevent destruction of the elements by static electricity, be careful to maintain an optimum work environment.

10.1.8.1 Be sure to ground the body when handling the LCD Modules.

10.1.8.2 Tools required for assembly, such as soldering irons, must be properly ground.

10.1.8.3 To reduce the amount of static electricity generated, do not conduct assembly and other work under dry conditions.

10.1.8.4 The LCD Module is coated with a film to protect the display surface. Be care when peeling off this protective film since static electricity may be generated.

10.2 Storage precautions

10.2.1 When storing the LCD modules, avoid exposure to direct sunlight or to the light of fluorescent lamps.

10.2.2 The LCD modules should be stored under the storage temperature range. If the LCD modules will be stored for a long time, the recommend condition is:

Temperature : 0°C ~ 40°C Relatively humidity: ≤80%

10.2.3 The LCD modules should be stored in the room without acid, alkali and harmful gas.

10.3 Transportation Precautions

10.3.1 The LCD modules should be no falling and violent shocking during transportation, and also should avoid excessive press, water, damp and sunshine.